



**Global
Pneumatics**

This icon can be found next to products that are widely supported by Parker Pneumatics' worldwide manufacturing and sales network. When you see this icon, you can be confident that this product is manufactured and/or stocked* worldwide for rapid delivery. In addition to local manufacturing or inventory, our sales network has been specifically trained on these products to provide our customers with the best possible service.

Products not showing this icon are still sold and distributed worldwide. However, The Global Pneumatics icon represents products that customers can expect the best level of support.

If you are a multi-national company, seek global sourcing or ship globally, depend on Parker Pneumatic for **PREMIER CUSTOMER SERVICE**.

* Stocking levels vary by country

⚠ WARNING

FAILURE OR IMPROPER SELECTION OR IMPROPER USE OF THE PRODUCTS AND/OR SYSTEMS DESCRIBED HEREIN OR RELATED ITEMS CAN CAUSE DEATH, PERSONAL INJURY AND PROPERTY DAMAGE.

This document and other information from Parker Hannifin Corporation, its subsidiaries and authorized distributors provide product and/or system options for further investigation by users having technical expertise. It is important that you analyze all aspects of your application including consequences of any failure, and review the information concerning the product or system in the current product catalog. Due to the variety of operating conditions and applications for these products or systems, the user, through its own analysis and testing, is solely responsible for making the final selection of the products and systems and assuring that all performance, safety and warning requirements of the application are met.

The products described herein, including without limitation, product features, specifications, designs, availability and pricing, are subject to change by Parker Hannifin Corporation and its subsidiaries at any time without notice.

Offer of Sale

The items described in this document are hereby offered for sale by Parker Hannifin Corporation, its subsidiaries or its authorized distributors. This offer and its acceptance are governed by the provisions stated on the separate page of this document entitled "Offer of Sale".



Contents

Features	F6	Dimensions.....	F18-F19
Ordering Information.....	F7	Options	F20-F24
Specifications	F8-F9	Sensors	F25
Engineering Data.....	F10-F17	Service Kits	F26

T
P5T
P5T2
P5TT/TD
P5L
HB
P5E

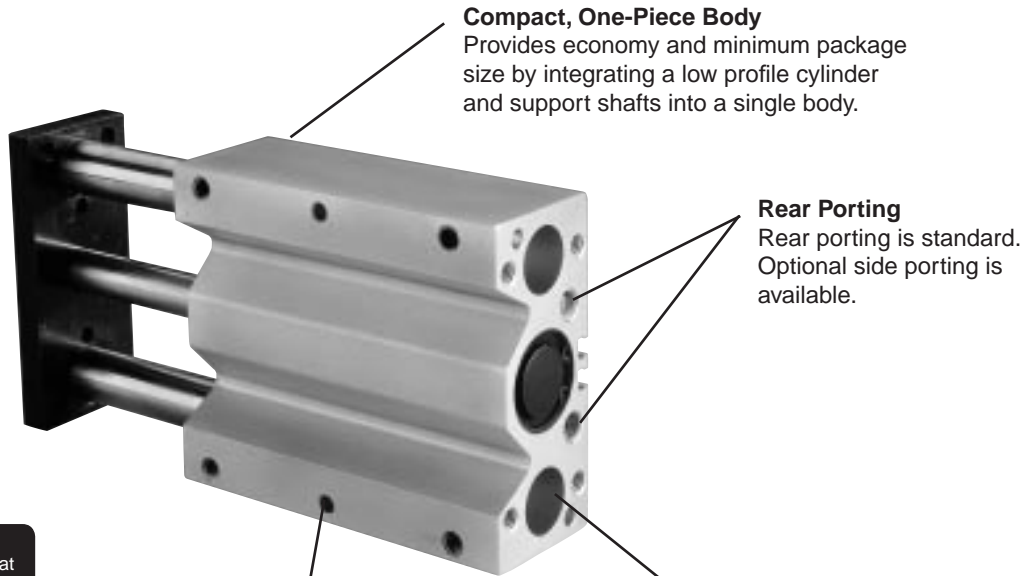

Compact, One-Piece Body
Provides economy and minimum package size by integrating a low profile cylinder and support shafts into a single body.

Rear Porting
Rear porting is standard. Optional side porting is available.

Internal Bumpers
Are standard on all units. These provide energy dissipation and noise reduction which result in longer operating life.

Standard Dowel Holes
Dowel holes on body provide simple, economical and precise mounting.

3D CAD FILES
available for download at parker.com/pneumatics

F

Top Porting
Top porting is standard. Optional side porting is available.

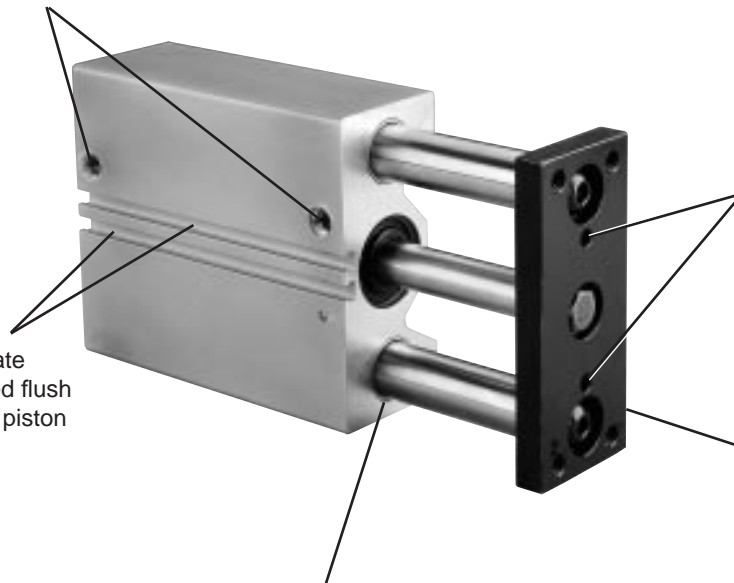

Dowel Holes
Standard dowel holes provide precision mounting and alignment on the tool plate.

Tooling Plate
Precision machined from steel, the tooling plate is thick and rigid to provide a durable connection.

Sensor Grooves
Allow reed or solid state sensors to be mounted flush to the body. Magnetic piston is standard.

Composite Bushings or Linear Ball Bearings
Parker uses a PTFE impregnated **composite bushing** which serves as a lubrication reservoir. This results in higher load carrying capabilities, both dynamic and static, with excellent resistance to shock loading. The impregnated lubricant also makes the bearings more dirt tolerant. **Composite bushings with oversized shafting** are available for high impact loads. Optional **recirculating ball bearings** provide precision operation with very low friction and wear.

Model Code and Ordering Information

Example: P5T-J032DHSN100

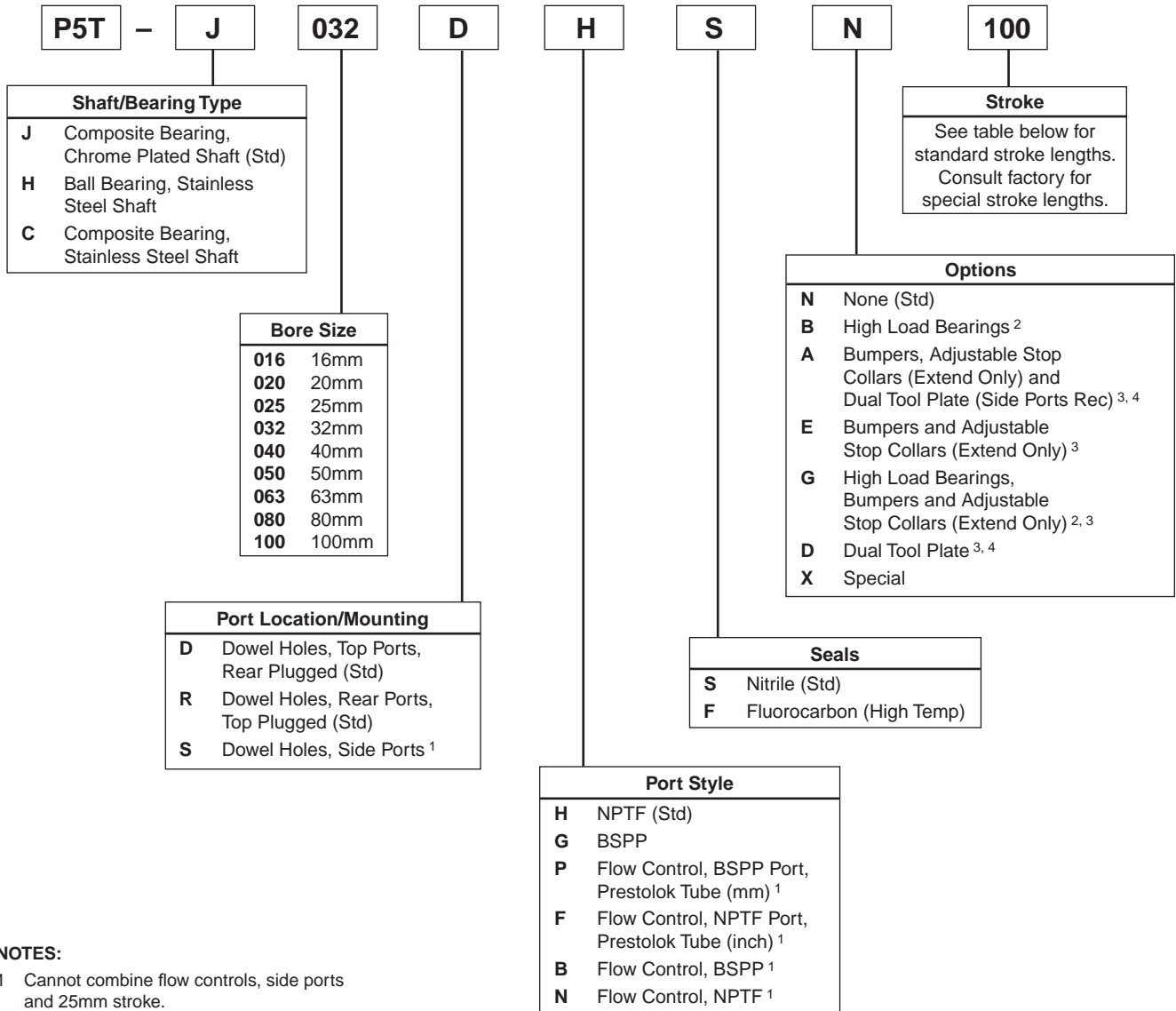

NOTES:

- 1 Cannot combine flow controls, side ports and 25mm stroke.
- 2 Not available with rear mounting and ports.
- 3 Not available with rear port location (R).
- 4 Includes high load bearings as standard.

Bore Size (mm)	Standard Strokes (mm)*									
	10	25	40	50	75	100	125	150	175	200
16	●	●	●	●	●	●				
20		●	●	●	●	●	●			
25		●		●	●	●	●	●		
32 - 100		●		●	●	●	●	●	●	●

*Consult factory for special stroke lengths.



Specifications

- Maximum operating pressure: 1 MPa (10 bar/145 psi)
- Operating characteristics: Double acting
- Support rod sizes: Ø8 to 35mm
- Mounting: Unrestricted
- Operating temperature range (cylinder):
 - Nitrile seals (standard) -18° to 74°C (0° to 165°F)
 - Fluorocarbon seals* -18° to 121°C (0° to 250°F)
- Filtration requirement: 40 micron, filtered dry air

* See Fluorocarbon seal option for high temperature applications.

Construction

Body Aluminum
 End Caps..... Aluminum
 Tool Plate..... Steel
 Piston Rod..... Stainless Steel
 Support Rods Steel (Chrome Plated)
 Rod Bolts..... Steel

Mounting Bolts

Bore Size	Socket Head Cap
16	M5 x .8
20	M5 x .8
25	M6 x 1.0
32	M8 x 1.25
40	M8 x 1.25
50	M10 x 1.5
63	M10 x 1.5
80	M12 x 1.75
100	M14 x 2.0

Note: When the P5T is used as an impact stopping system, mounting bolt thread engagement should be 1.5 times bolt diameter.



Quick Reference Data

Model (Bore Size)	Piston Rod (mm)	Bushings	Support Rods (mm)	Piston Bore Area Non-Rod Side		Max Stroke (mm)	Theoretical Force			
				mm ²	in ²		Extend @75 PSI (0.5 MPa)		Retract @75 PSI (0.5 MPa)	
							N	lb	N	lb
16	8	Ball	8	200	0.31	100	105	23.6	77.4	17.4
		Composite	10	200	0.31	100	105	23.6	77.4	17.4
20	10	Ball	10	316	0.49	125	164	36.8	123	27.8
		Composite	12	316	0.49	125	164	36.8	123	27.8
25	10	Ball	12	490	0.76	150	254	57	213.5	48
		Composite	16	490	0.76	150	254	57	213.5	48
32	16	Ball	16	804	1.25	200	402	93	302	70
		Composite	20	804	1.25	200	402	93	302	70
40	16	Ball	16	1257	1.95	200	628	146	528	123
		Composite	20	1257	1.95	200	628	146	528	123
50	20	Ball	20	1964	3.04	200	982	228	825	192
		Composite	25	1964	3.04	200	982	228	825	192
63	20	Ball	20	3117	4.83	200	1559	362	1492	326
		Composite	25	3117	4.83	200	1559	362	1492	326
80	25	Ball	25	5027	7.79	200	2513	584	2268	527
		Composite	30	5027	7.79	200	2513	584	2268	527
100	25	Ball	30	7854	12.17	200	3927	913	3574	856
		Composite	35	7854	12.17	200	3927	913	3574	856

Weights

Units with Composite Bushings

Weights in kg (lb)

Model	Standard Stroke (mm)									
	10	25	40	50	75	100	125	150	175	200
16	0.35 (0.77)	0.43 (0.95)	0.51 (1.13)	0.57 (1.25)	0.70 (1.54)	0.84 (1.84)	—	—	—	—
20	—	0.76 (1.66)	0.86 (1.90)	0.94 (2.06)	1.11 (2.45)	1.29 (2.85)	1.47 (3.24)	—	—	—
25	—	1.13 (2.48)	—	1.39 (3.05)	1.65 (3.63)	1.91 (4.20)	2.17 (4.77)	2.43 (5.35)	—	—
32	—	1.67 (3.68)	—	2.07 (4.55)	2.46 (5.42)	2.86 (6.29)	3.26 (7.17)	3.65 (8.04)	4.05 (8.91)	4.45 (9.78)
40	—	2.00 (4.40)	—	2.42 (5.32)	2.84 (6.25)	3.26 (7.17)	3.68 (8.10)	4.10 (9.02)	4.52 (9.94)	4.84 (10.65)
50	—	2.63 (5.78)	—	3.22 (7.08)	3.81 (8.38)	4.40 (9.69)	4.99 (10.99)	5.59 (12.29)	6.18 (13.59)	6.77 (14.89)
63	—	3.29 (7.24)	—	3.98 (8.75)	4.66 (10.25)	5.34 (11.75)	6.02 (13.25)	6.71 (14.76)	7.39 (16.26)	8.07 (17.76)
80	—	6.06 (13.33)	—	7.12 (15.66)	8.18 (18.00)	9.24 (20.33)	10.30 (22.66)	11.36 (24.99)	12.42 (27.33)	13.48 (29.66)
100	—	10.69 (23.52)	—	12.03 (26.47)	13.37 (29.42)	14.71 (32.37)	16.05 (35.32)	17.39 (38.27)	18.73 (41.22)	20.08 (44.17)

Units with Linear Ball Bushings

Weights in kg (lb)

Model	Standard Stroke (mm)									
	10	25	40	50	75	100	125	150	175	200
16	0.32 (0.70)	0.39 (0.86)	0.46 (1.02)	0.51 (1.13)	0.64 (1.40)	0.76 (1.67)	—	—	—	—
20	—	0.70 (1.53)	0.80 (1.75)	0.86 (1.90)	1.03 (2.26)	1.19 (2.62)	1.36 (2.99)	—	—	—
25	—	0.98 (2.15)	—	1.20 (2.64)	1.43 (3.14)	1.65 (3.64)	1.88 (4.14)	2.11 (4.63)	—	—
32	—	1.51 (3.31)	—	1.86 (4.09)	2.21 (4.86)	2.56 (5.63)	2.91 (6.41)	3.27 (7.18)	3.62 (7.96)	3.97 (8.73)
40	—	1.82 (4.01)	—	2.20 (4.83)	2.57 (5.66)	2.95 (6.49)	3.32 (7.31)	3.70 (8.14)	4.08 (8.97)	4.45 (9.79)
50	—	2.35 (5.17)	—	2.87 (6.32)	3.39 (7.47)	3.92 (8.62)	4.44 (9.76)	4.96 (10.91)	5.48 (12.06)	6.01 (13.21)
63	—	2.99 (6.58)	—	3.60 (7.93)	4.22 (9.28)	4.83 (10.63)	5.45 (11.98)	6.06 (13.33)	6.67 (14.68)	7.29 (16.03)
80	—	5.66 (12.45)	—	6.63 (14.59)	7.61 (16.74)	8.58 (18.88)	9.56 (21.03)	10.53 (23.18)	11.51 (25.32)	12.49 (27.47)
100	—	10.16 (22.36)	—	11.40 (25.09)	12.64 (27.82)	13.89 (30.55)	15.13 (33.28)	16.37 (36.01)	17.61 (38.74)	18.85 (41.46)



**Horizontal Load Capacity
Standard Unit**

P5T Series units will have the same load capacity regardless of orientation. The graphs below show maximum load capacity based on a unit life of 10 million cycles .

EXAMPLE: A P5T-16 with “stroke + d” of 75mm and composite bushings would have a load capacity of 50N.

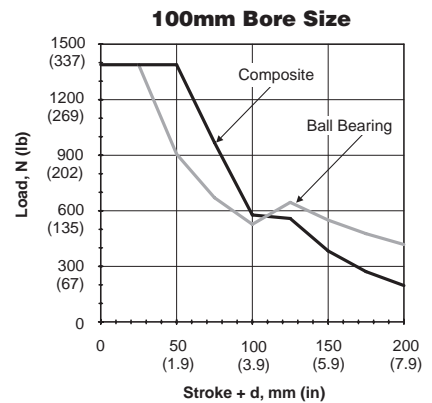
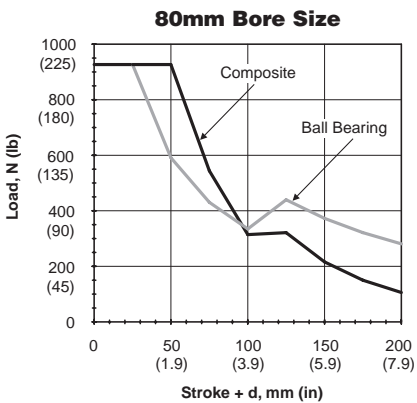
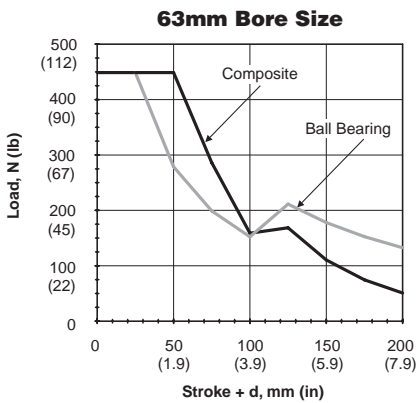
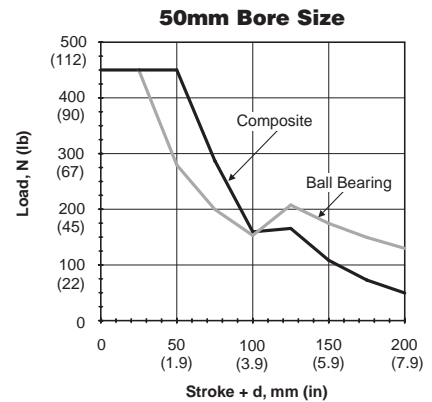
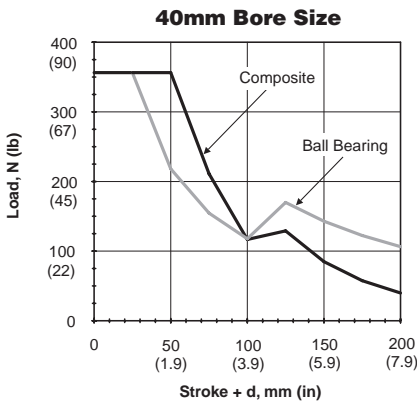
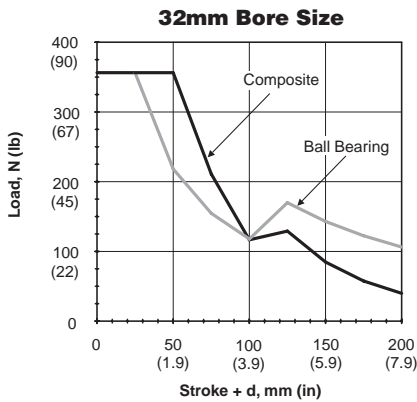
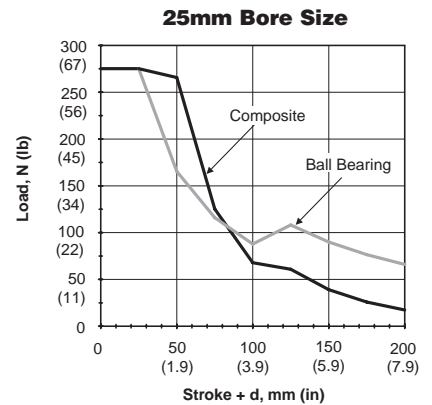
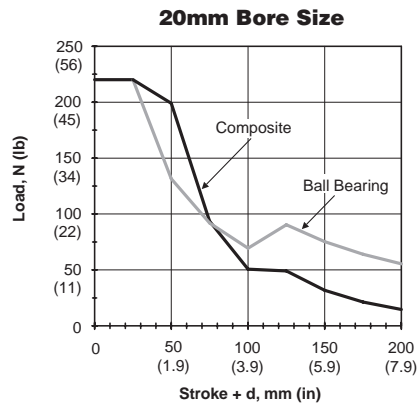
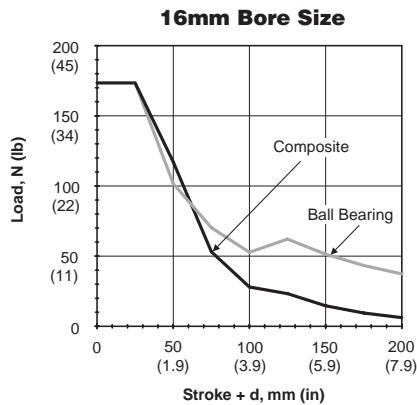
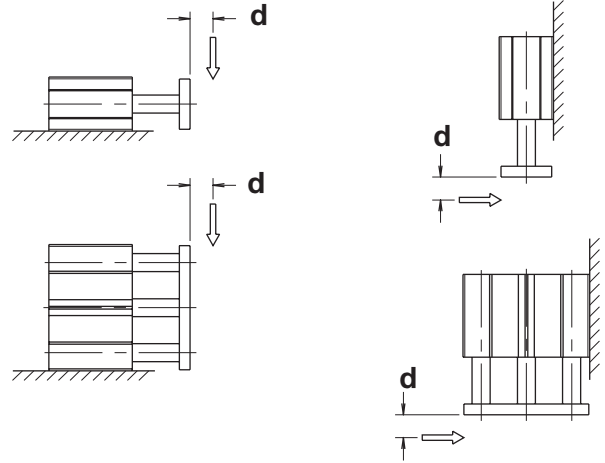

Horizontal Load Capacity with High Load Bearings and Dual Tool Plate (D, A, B)

P5T Series units will have the same load capacity regardless of orientation. The graphs below show maximum load capacity based on a unit life of 10 million cycles.

EXAMPLE: A P5T-20 with “stroke + d” of 100mm and high load composite bushings would have a load capacity of 125N.

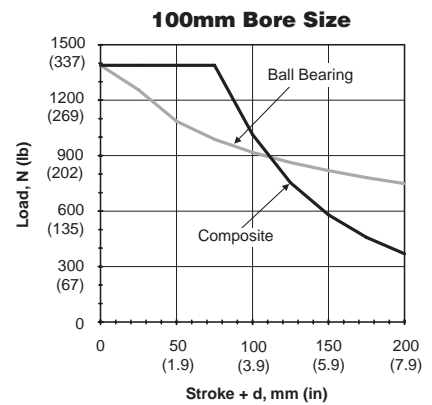
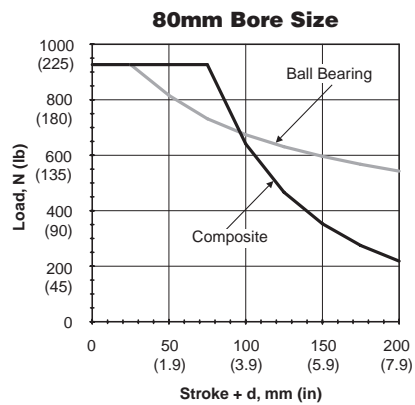
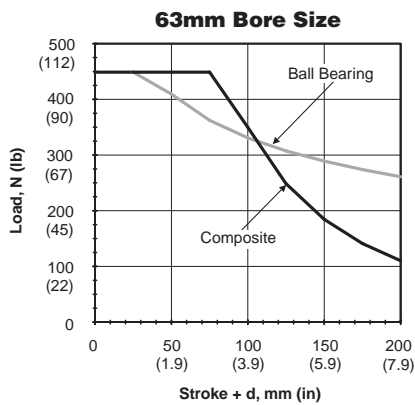
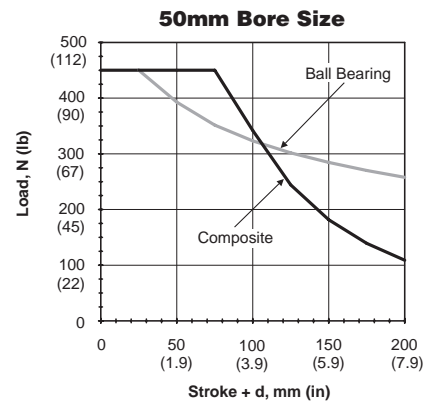
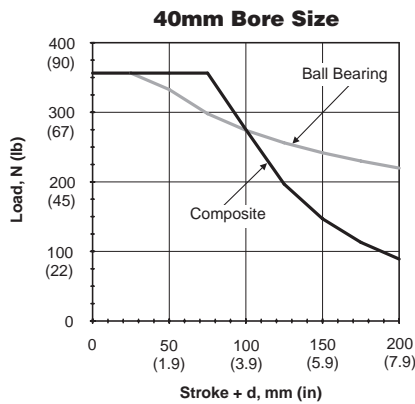
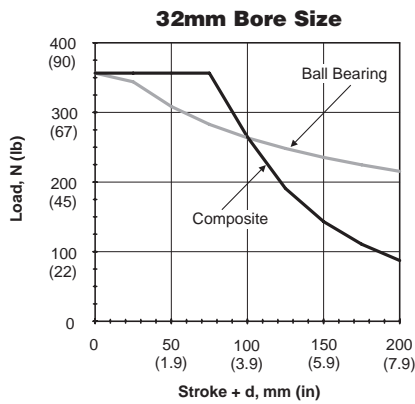
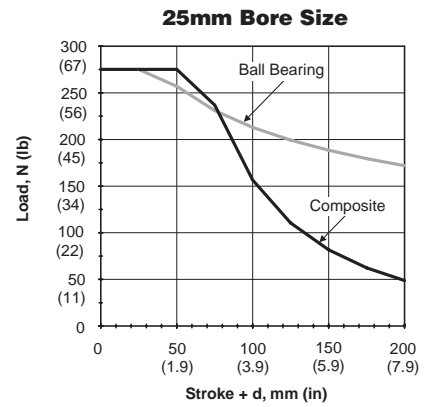
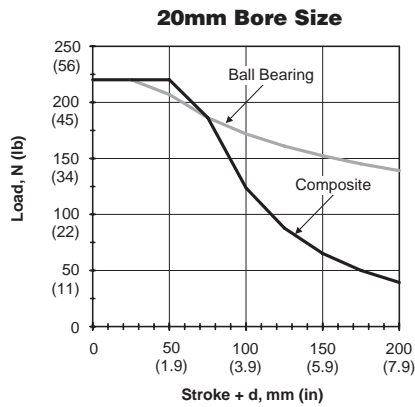
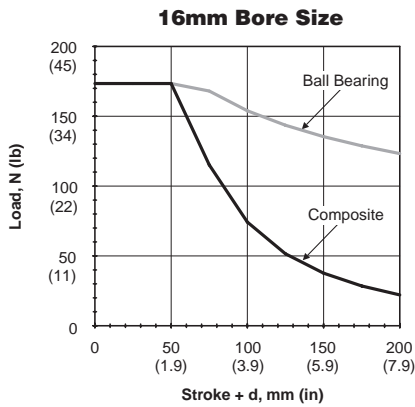
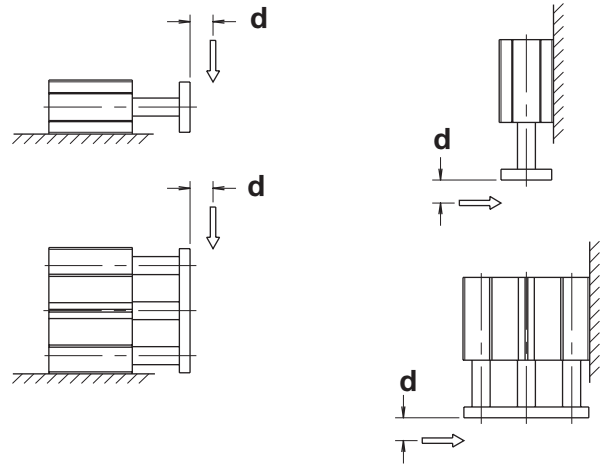

**Load Stopping Capacity
Standard Unit**

P5T Series actuators are ideal for conveyor stopping applications. Units can be mounted horizontally or vertically.

Composite bushings are strongly recommended for this type of application.

EXAMPLE: A P5T-50 unit with a stroke up to 50mm will stop an object moving at 40 cm/second (15.75 in/s) that weighs up to 50 kg (110 lb).

Note: The following graphs are based on 50mm of stroke.

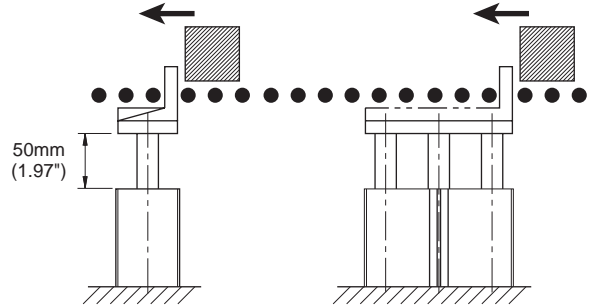

16mm Bore Size

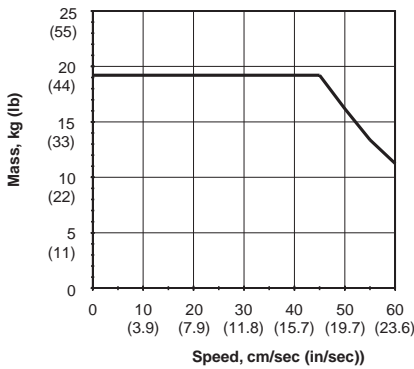

20mm Bore Size

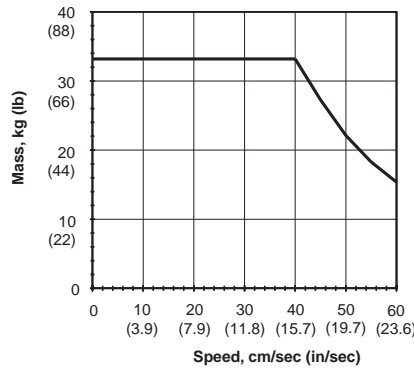

25mm Bore Size

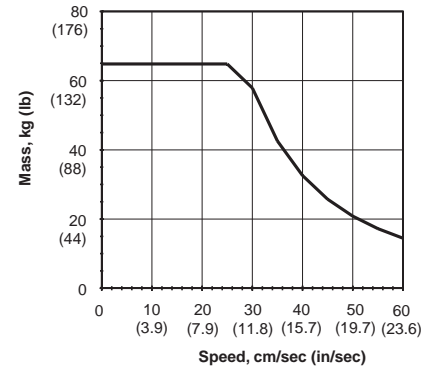

32mm Bore Size

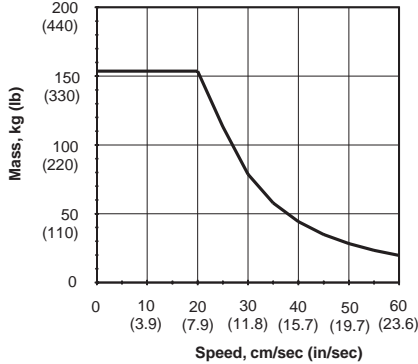

40mm Bore Size

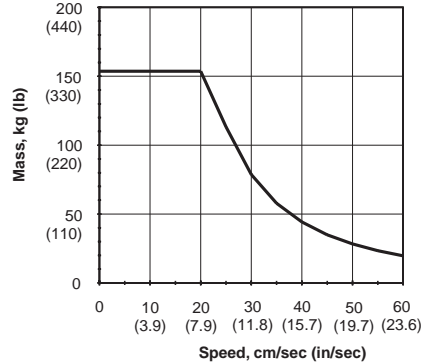

50mm Bore Size

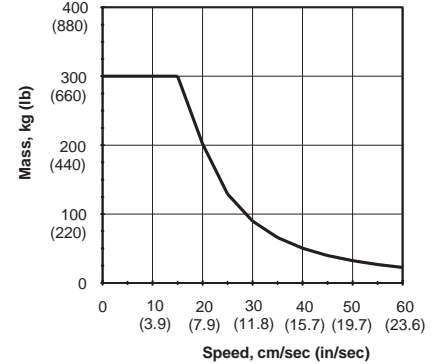

63mm Bore Size

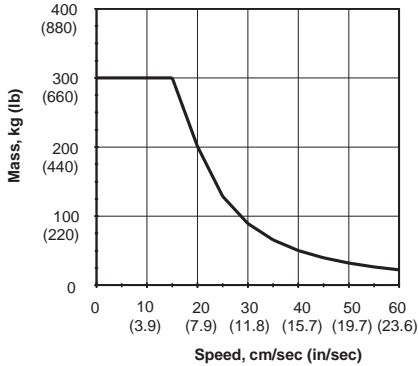

80mm Bore Size

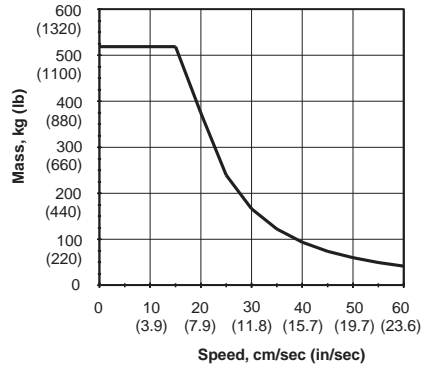

100mm Bore Size

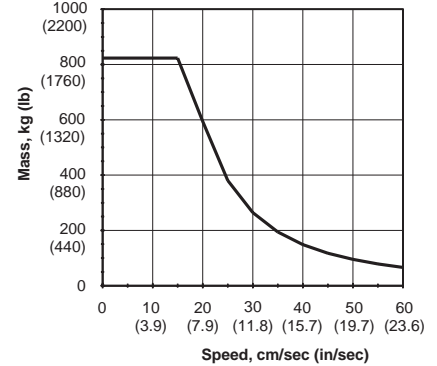

Load Stopping Capacity with High Load Bearings and Dual Tool Plate (D, A, B)

P5T Series actuators are ideal for conveyor stopping applications. Units can be mounted horizontally or vertically.

Composite bushings are strongly recommended for this type of application.

EXAMPLE: A P5T-25 unit with a stroke up to 50mm will stop an object moving at 40 cm/second (15.7 in/s) that weighs up to 46 kg (101 lb).

Note: The following graphs are based on 50mm of stroke.

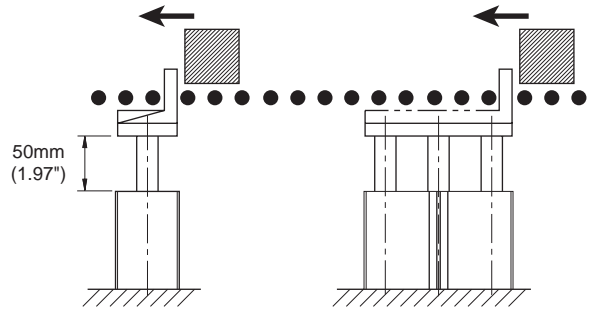

16mm Bore Size

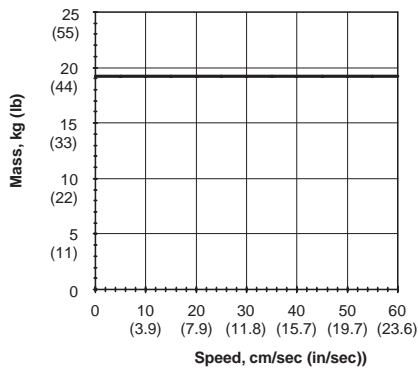

20mm Bore Size

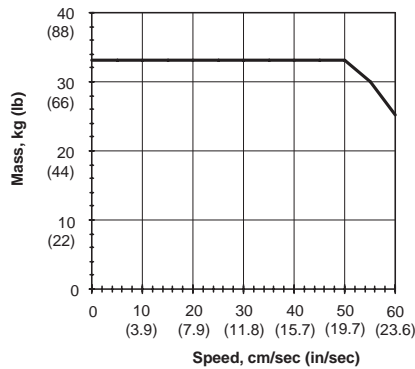

25mm Bore Size

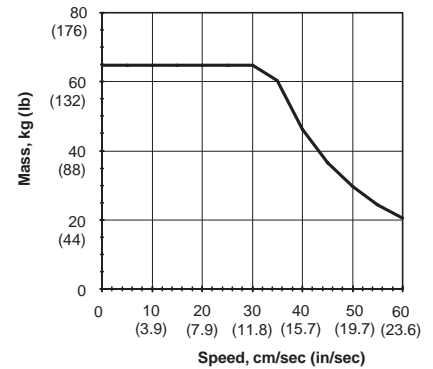

32mm Bore Size

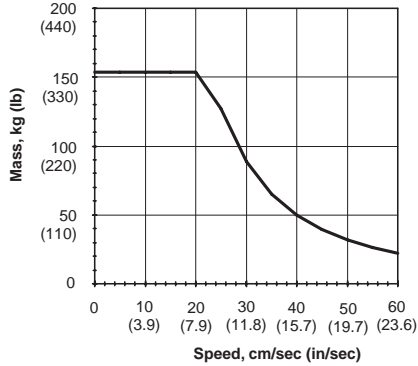

40mm Bore Size

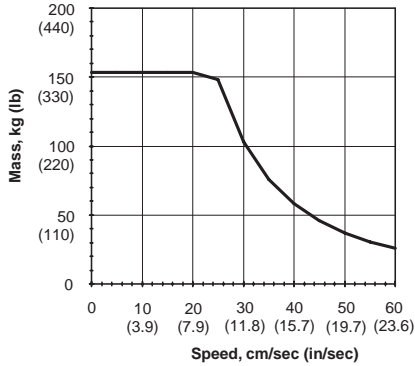

50mm Bore Size

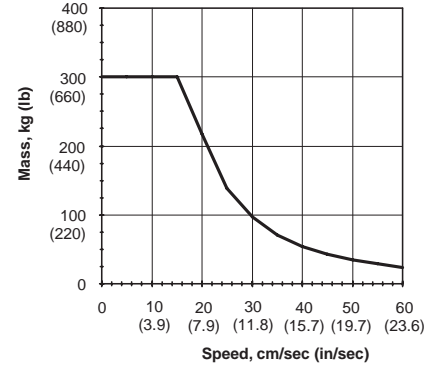

63mm Bore Size

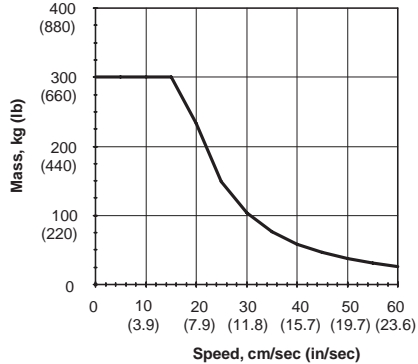

80mm Bore Size

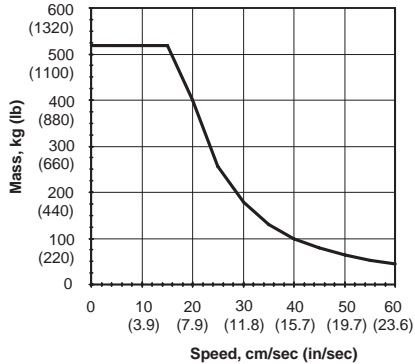

100mm Bore Size

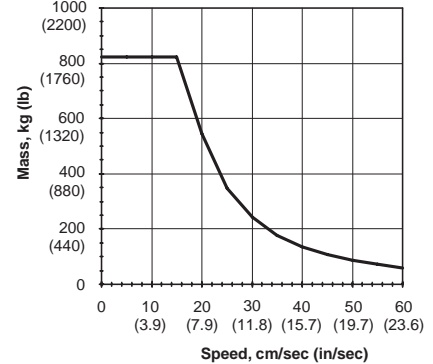

Asymmetrical Torque Capacity Standard Unit

Asymmetrical loading occurs when the load is applied to one side of the unit. P5T Series units can resist torsional loads that are asymmetrical.

EXAMPLE: A mechanism exerts an asymmetrical load of 15Nm on a P5T-50 with 50mm “stroke+d”. The P5T-50 with composite bushings will have adequate torsional capacity.

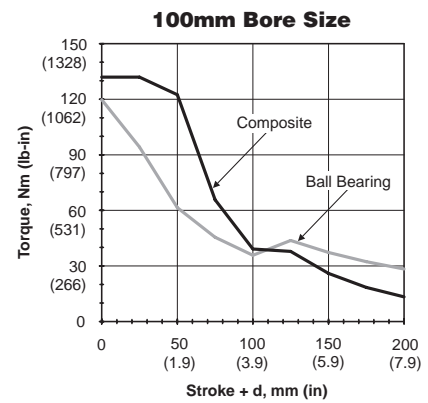
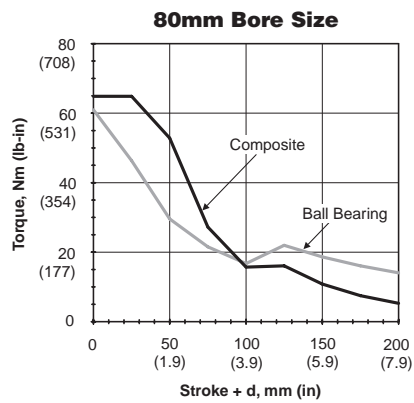
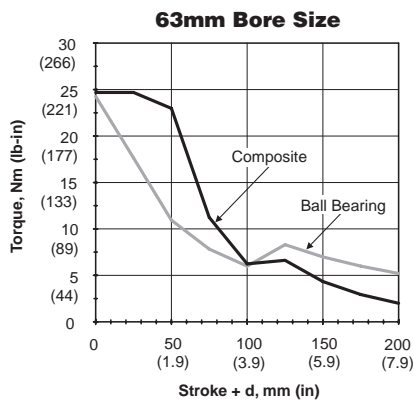
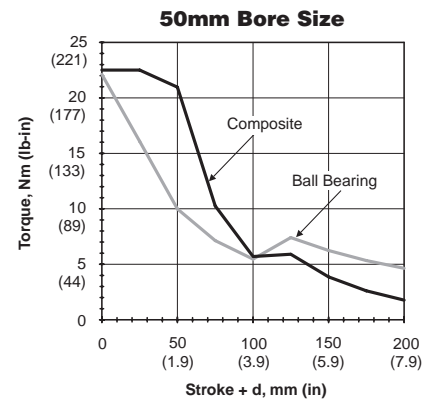
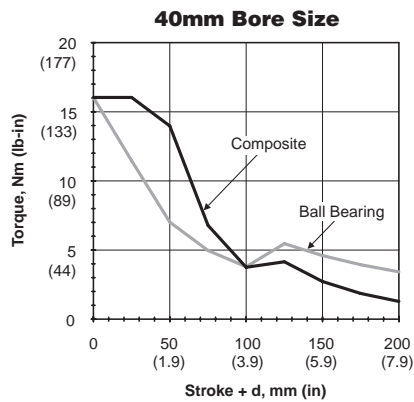
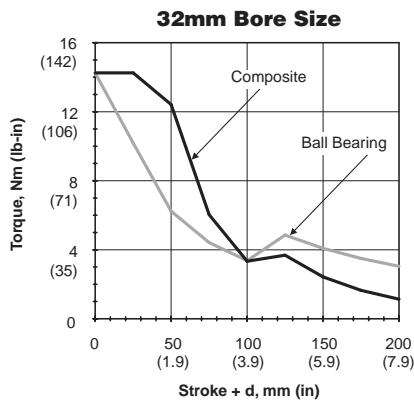
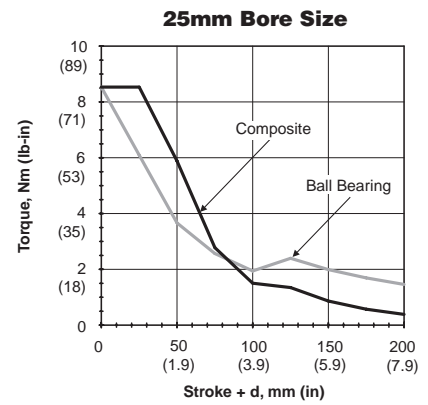
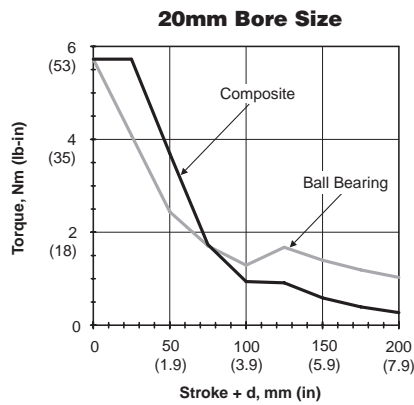
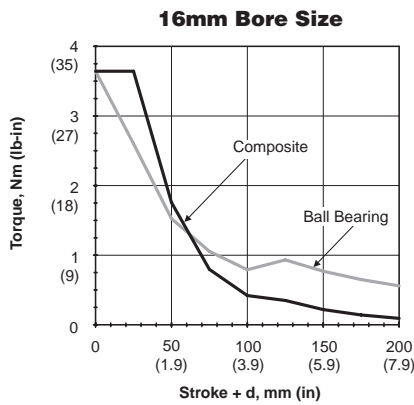
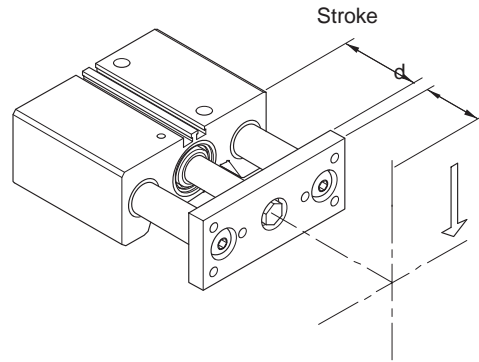

F

Asymmetrical Torque Capacity with High Load Bearings and Dual Tool Plate (D, A, B)

Asymmetrical loading occurs when the load is applied to one side of the unit. P5T Series units can resist torsional loads that are asymmetrical.

EXAMPLE: A mechanism exerts an asymmetrical load of 15Nm on a P5T-50 with 50mm “stroke+d”. The P5T-50 with composite bushings will have adequate torsional capacity.

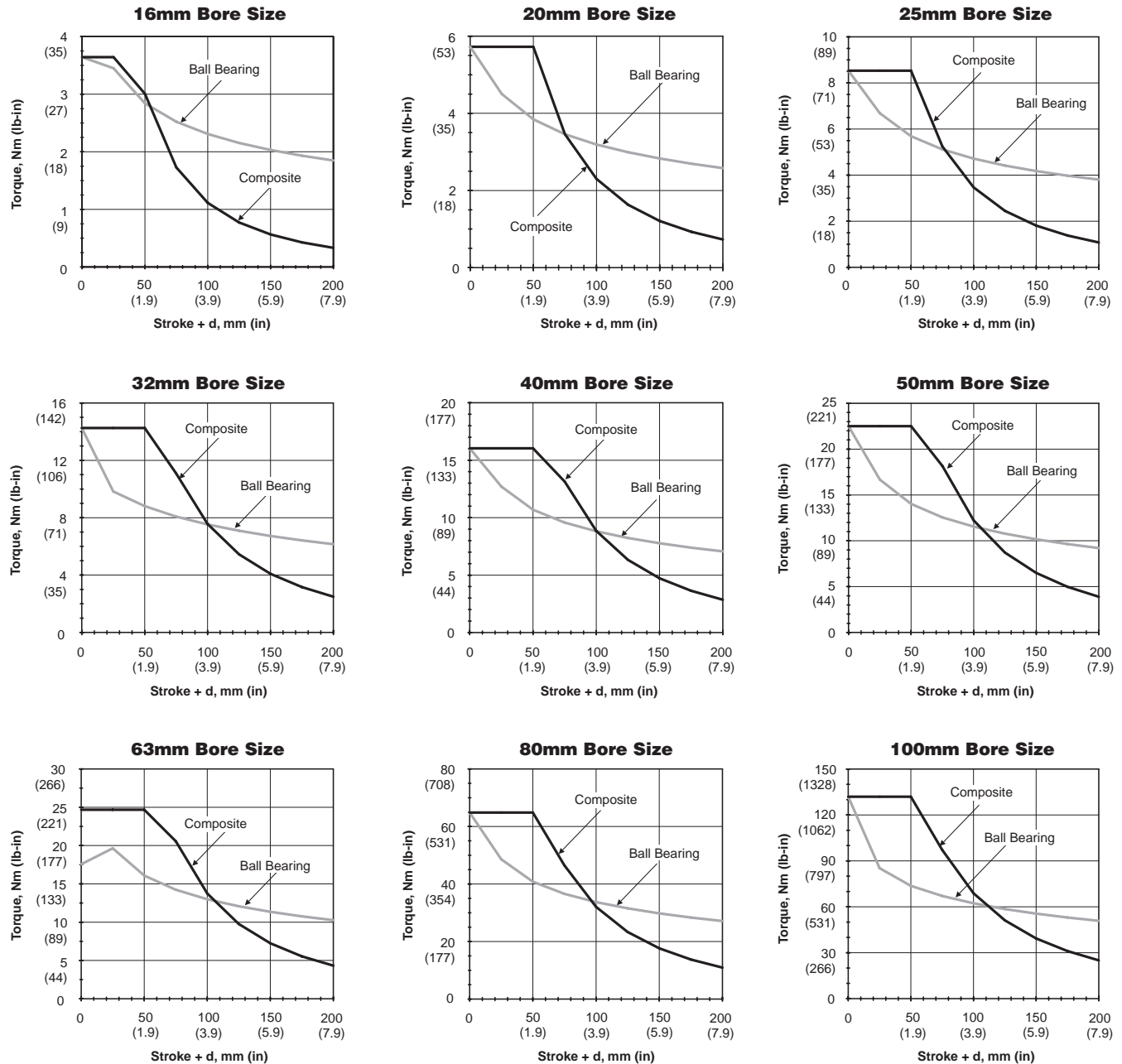
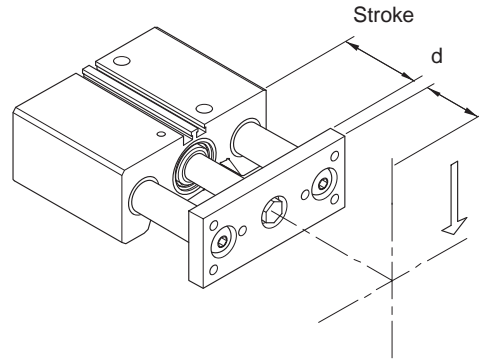

P5T
P5T2
P5TT/TD
P5L
HB
P5E

Vertical Eccentric Load Capacity Standard Unit

P5T Series units mounted vertically will have the same eccentric load capacity regardless of orientation. The graphs provide maximum load capacity for an eccentric mounted load. The load is assumed to be mounted at the face of the tooling plate.

These load curves illustrate load ratings based on the bearing system of the product. Load rating is a key selection criterion but is not the only one to consider in the selection of a product.

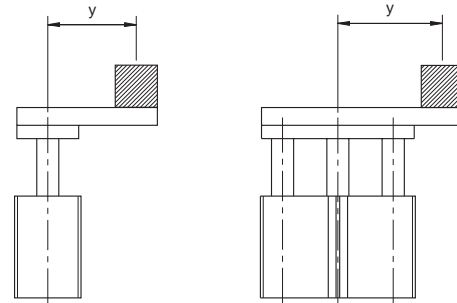

$y = \text{eccentricity distance}$

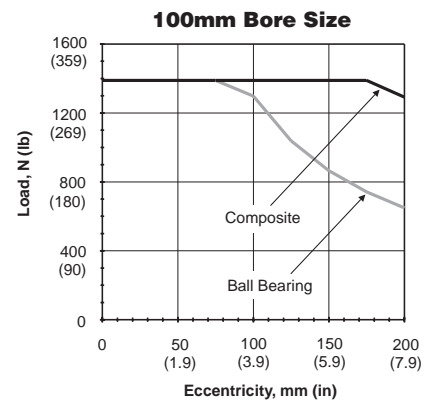
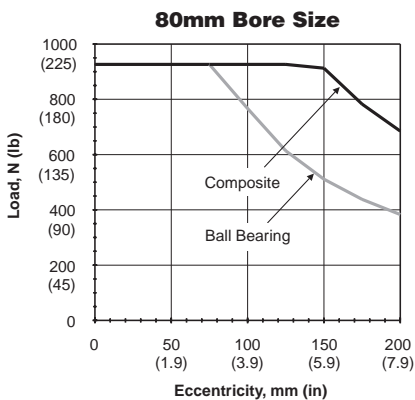
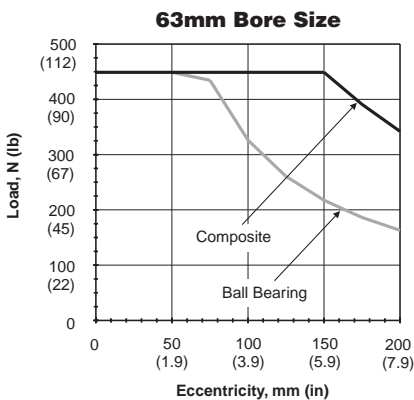
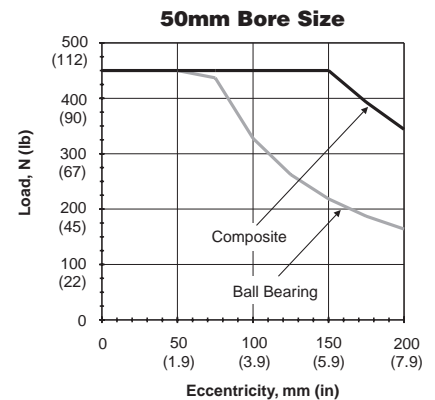
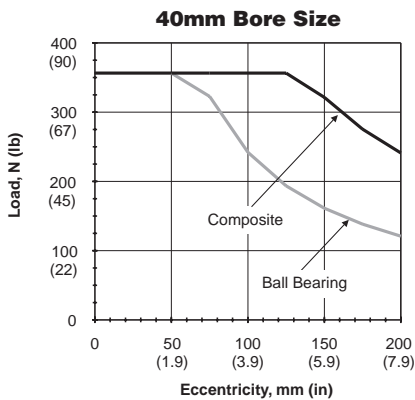
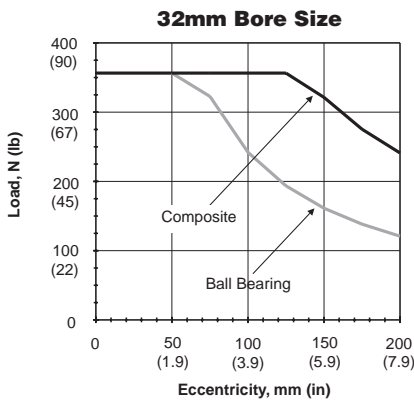
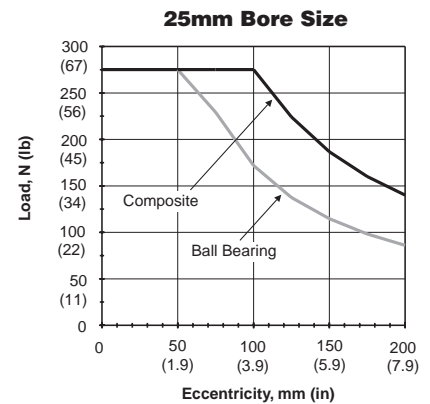
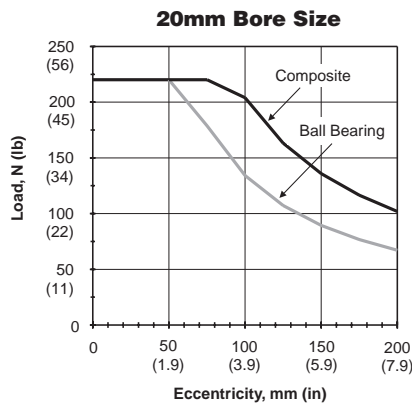
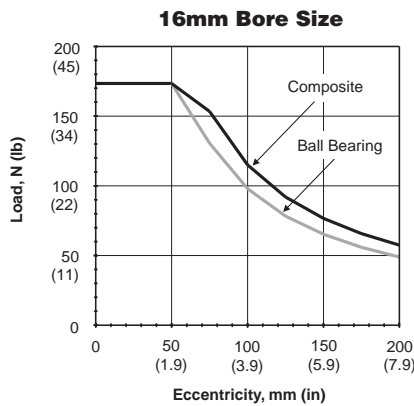

F

Vertical Eccentric Load Capacity with High Load Bearings and Dual Tool Plate (D, A, B)

P5T Series units mounted vertically will have the same eccentric load capacity regardless of orientation. The graphs provide maximum load capacity for an eccentric mounted load. The load is assumed to be mounted at the face of the tooling plate.

These load curves illustrate load ratings based on the bearing system of the product. Load rating is a key selection criterion but is not the only one to consider in the selection of a product.

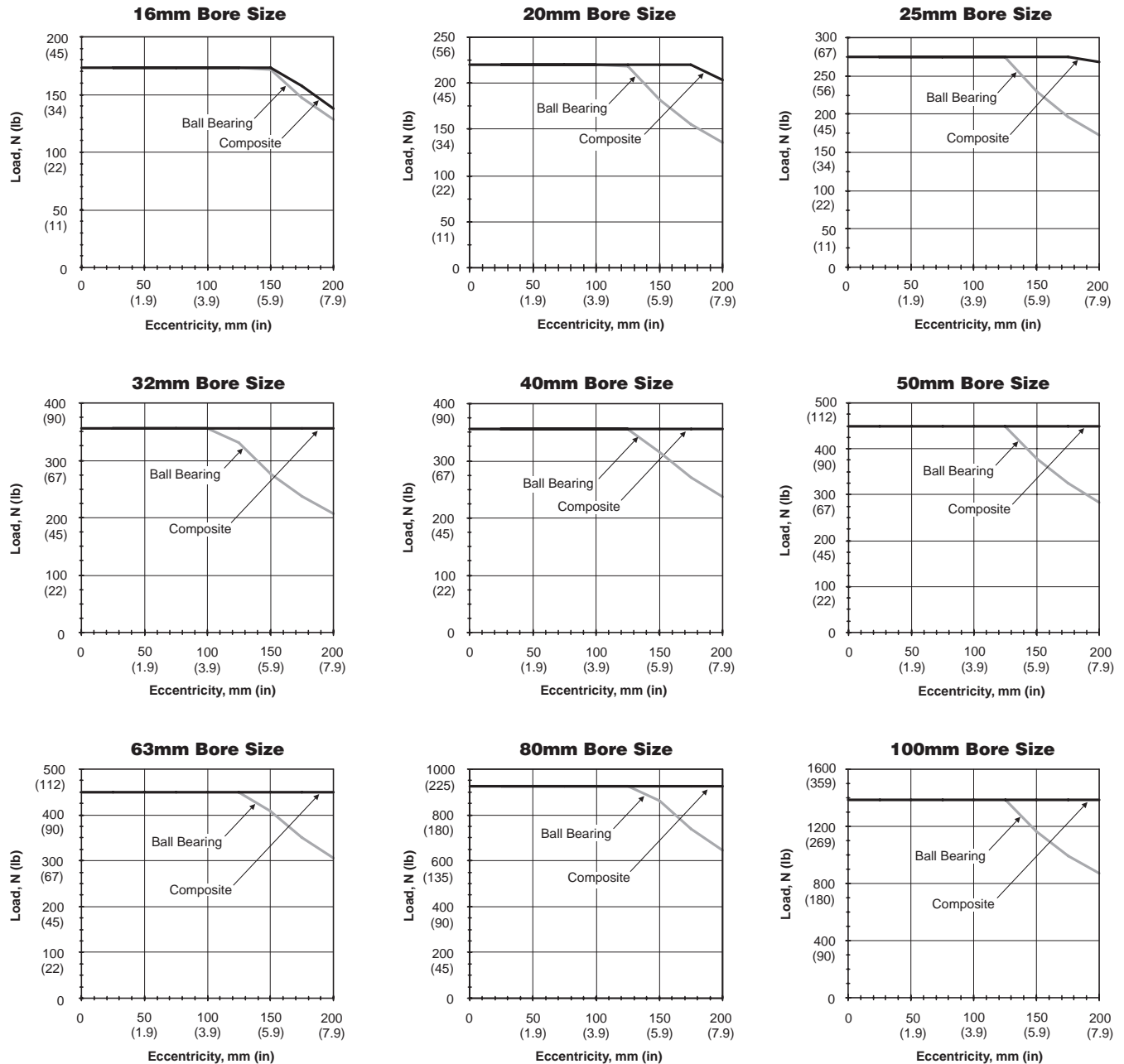
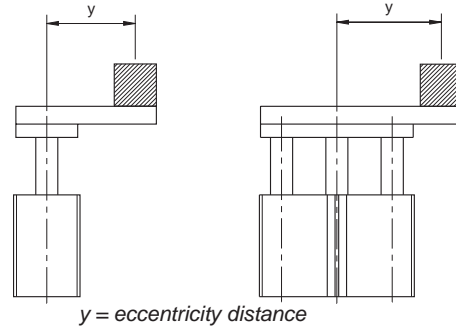

Basic Unit

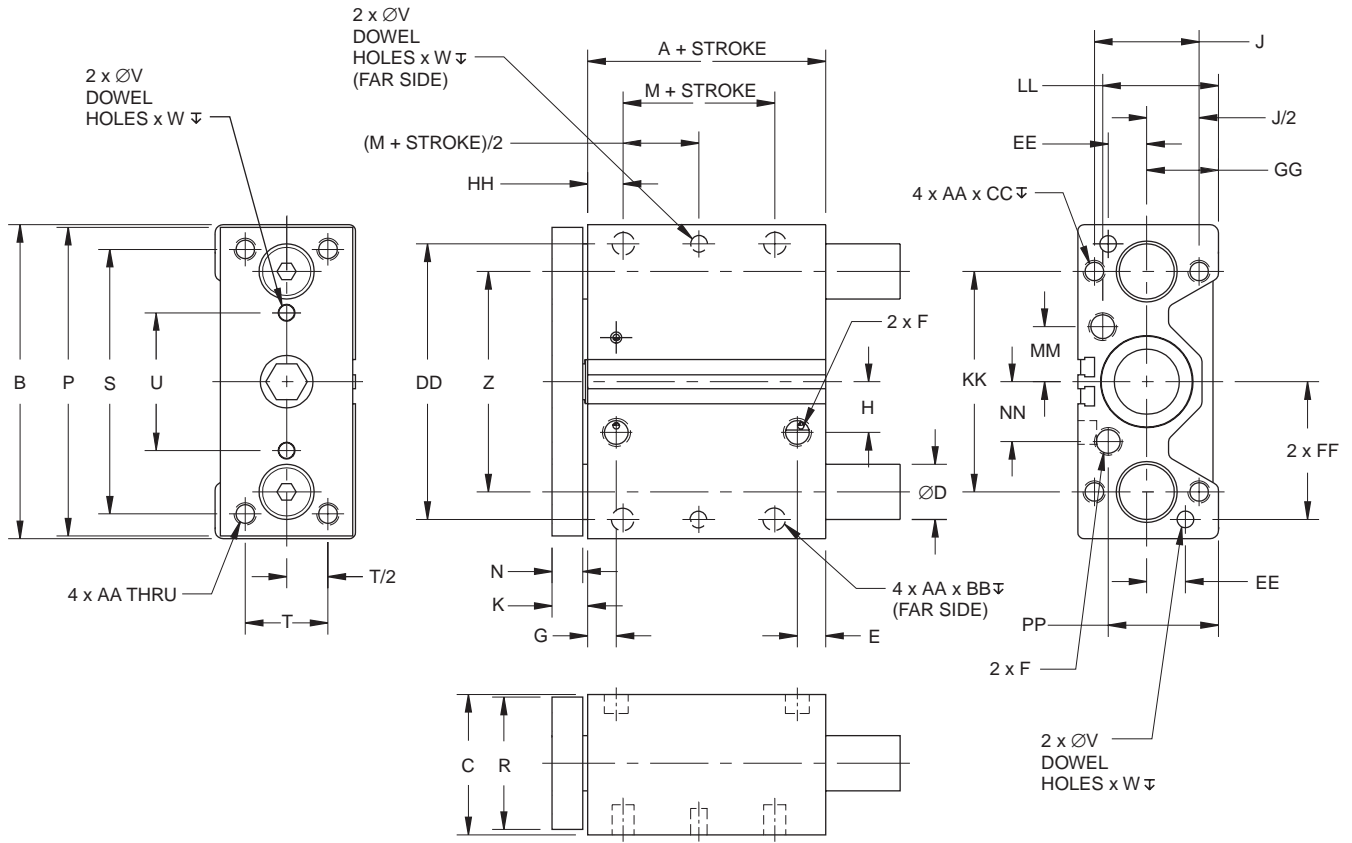

3D CAD FILES
 available for download at
parker.com/pneumatics

Note: On 16mm bore size only, one sensor groove is available.
 When utilizing two sensors on the 16mm bore size with 25mm stroke or less, use right angle short sensors.

Basic Unit

Model	A**	B	C	D ¹	D ²	E**	F		G	H	J	K
16	37.75 (1.49)	64 (2.52)	31 (1.22)	8 (0.315)	10 (0.394)	10.1 (0.40)	M5/10-32		10.1 (0.40)	6.95 (0.27)	22 (0.866)	9.94 (0.39)
20	36 (1.42)	74 (2.91)	36 (1.42)	10 (0.394)	12 (0.472)	19 (0.75)	1/8 NPTF OR BSPP		10 (0.39)	15.8 (0.62)	26 (1.024)	9.94 (0.39)
25	38 (1.50)	88 (3.46)	42 (1.65)	12 (0.472)	16 (0.630)	21 (0.83)	1/8 NPTF OR BSPP		11.4 (0.45)	15.5 (0.61)	32 (1.260)	9.94 (0.39)
32	36 (1.42)	114 (4.49)	51 (2.00)	16 (0.630)	20 (0.787)	10.26 (0.40)	1/8 NPTF OR BSPP		10.35 (0.41)	18.42 (0.73)	38 (1.496)	13.1 (0.52)
40	44 (1.73)	124 (4.88)	52 (2.05)	16 (0.630)	20 (0.787)	12.10 (0.48)	1/8 NPTF OR BSPP		14.9 (0.59)	22.53 (0.89)	38 (1.496)	13.1 (.052)
50	44.9 (1.77)	140 (5.51)	62 (2.44)	20 (0.787)	25 (0.984)	14.5 (0.57)	1/4 NPTF OR BSPP		16.1 (0.63)	27 (1.06)	44 (1.732)	14.7 (0.58)
63	50.05 (1.97)	150 (5.91)	75 (2.95)	20 (0.787)	25 (0.984)	16.4 (0.65)	1/4 NPTF OR BSPP		14.5 (0.57)	33 (1.30)	44 (1.732)	14.7 (0.58)
80	60.3 (2.37)	188 (7.40)	95 (3.74)	25 (0.984)	30 (1.181)	17.5 (0.610)	3/8 NPTF OR BSPP		19 (0.75)	37 (1.46)	56 (2.205)	18 (0.71)
100**	67.5 (2.60)	224 (8.82)	115 (4.53)	30 (1.181)	35 (1.38)	21.9 (0.862)	3/8 NPTF OR BSPP		23 (0.91)	40 (1.57)	62 (2.441)	18 (0.71)
Model	M	N	P	R	S	T	U	V	W	Z	AA	BB
16	7 (0.276)	7.94 (0.31)	62 (2.44)	25.4 (1.00)	52 (2.047)	16 (.630)	20 (0.787)	3 (0.118)	6 (0.236)	42 (1.654)	M5 X 0.8	7.5 (0.30)
20	10 (0.394)	7.94 (0.31)	72 (2.83)	31.8 (1.25)	60 (2.362)	18 (.709)	30 (1.181)	4 (0.157)	6 (0.236)	52 (2.047)	M5 X 0.8	7.5 (0.30)
25	10 (0.394)	7.94 (0.31)	86 (3.39)	38 (1.50)	70 (2.756)	26 (1.024)	34 (1.339)	4 (0.157)	6 (0.236)	62 (2.441)	M6 X 1.0	9 (0.35)
32	5 (0.197)	11.1 (0.44)	112 (4.41)	44.5 (1.75)	96 (3.780)	30 (1.181)	50 (1.969)	6 (0.236)	6 (0.236)	80 (3.150)	M8 X 1.25	11 (0.43)
40	10 (0.394)	11.1 (0.44)	122 (4.80)	44.5 (1.75)	106 (4.173)	30 (1.181)	60 (2.362)	6 (0.236)	6 (0.236)	90 (3.543)	M8 X 1.25	11 0.43)
50	10 (0.394)	12.7 (0.50)	138 (5.43)	57.2 (2.25)	120 (4.724)	40 (1.575)	60 (2.362)	8 (0.315)	8 (0.315)	100 (3.937)	M10 X 1.5	12 (0.47)
63	10 (0.394)	12.7 (0.50)	148 (5.83)	69.9 (2.75)	130 (5.118)	50 (1.969)	72 (2.835)	8 (0.315)	8 (0.315)	110 (4.331)	M10 X 1.5	15 (0.59)
80	15 (0.591)	16 (0.63)	185 (7.28)	89 (3.50)	160 (6.299)	60 (2.362)	92 (3.622)	10 (0.394)	10 (0.394)	140 (5.512)	M12 X 1.75	18 (0.71)
100	15 (0.591)	16 (0.63)	221 (8.70)	108 (4.25)	190 (7.480)	80 (3.150)	114 (4.488)	10 (0.394)	10 (0.394)	170 (6.693)	M14 X 2.0	21 (0.83)
Model	CC	DD	EE	FF	GG	HH	KK	LL	MM	NN	PP	Piston Rod
16	10 (0.39)	54 (2.126)	8 (0.315)	27 (1.063)	15 (0.591)	13.06 (0.514)	42 (1.654)	22.5 (0.88)	11.25 (0.44)	9.7 (0.38)	23.0 (0.91)	8 (0.315)
20	10 (0.39)	64 (2.520)	10 (0.394)	32 (1.260)	17 (0.669)	13.06 (0.514)	52 (2.126)	26.0 (1.02)	15.4 (0.61)	15.4 (0.61)	26.0 (1.0)	10 (0.394)
25	12 (0.47)	76 (2.992)	11 (0.433)	38 (1.496)	21 (0.827)	14.06 (0.553)	62 (2.441)	33.4 (1.31)	17 (0.67)	17 (0.67)	33.4 (1.31)	10 (0.394)
32	16 (0.63)	100 (3.937)	14 (0.551)	50 (1.969)	26 (1.024)	12.9 (0.508)	80 (3.150)	42 (1.65)	20 (0.79)	21.7 (0.85)	38 (1.50)	16 (0.630)
40	16 (0.63)	110 (4.33)	14 (0.551)	55 (2.165)	26 (1.024)	13.9 (0.547)	90 (3.543)	41 (1.61)	24 (0.95)	26.4 (1.04)	37.9 (1.49)	16 (0.630)
50	20 (0.79)	124 (4.882)	16 (0.630)	62 (2.441)	30 (1.181)	14.3 (0.563)	100 (3.937)	51 (2.01)	29 (1.14)	33 (1.30)	44 (1.73)	20 (0.787)
63	20 (0.79)	132 (5.197)	18 (0.709)	66 (2.598)	36.5 (1.437)	16.3 (0.642)	110 (4.331)	62 (2.44)	36 (1.42)	37.75 (1.49)	57.75 (2.27)	20 (0.787)
80	24 (0.94)	166 (6.535)	22 (0.866)	83 (3.268)	46.5 (1.831)	21 (0.83)	140 (5.512)	78 (3.07)	45 (1.77)	48 (1.89)	75.5 (2.97)	25 (0.984)
100	28 (1.10)	200 (7.874)	24 (0.945)	100 (3.937)	56.5 (2.224)	25 (0.98)	170 (6.693)	91.5 (3.60)	53 (2.09)	51 (2.01)	95.5 (3.76)	25 (0.984)

D¹ With linear ball bearing D² With composite bushing
** For Model 100 with 25mm stroke, A = 100.3 (3.95") and E = 28 (1.10")

All dimensions in mm (inch)



Options

Shaft Bearings

Composite bushings are supplied as standard.
Linear ball bearings are optional.

Selection should be based on the following criteria:

Application Requirement	Ball	Composite
Precision	Excellent	Good
Friction	Low	Higher
Friction coefficient	Constant	Variable
Precision over life of bearing	Constant	Variable
Static Load Capacity	Good	Excellent
Dynamic Load Capacity	Good	Good with lower efficiency
Vibration Resistance	Fair	Excellent
Contamination Resistance	Poor	Excellent
Washdown Compatibility	Poor	Excellent

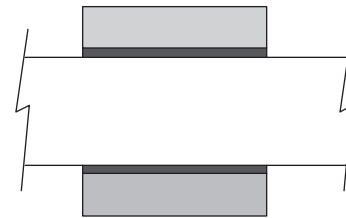

Composite Bushing (J,C)

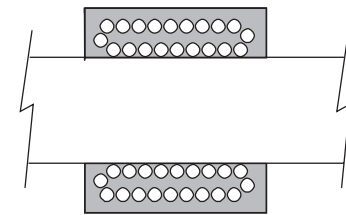

Recirculating Ball Bearing (H)

For bearing load capacities, reference the Engineering Data section.

F

Corrosion Resistant Shafting (C, H)

Chrome-plated case hardened, high carbon alloy steel shafting with composite bearings is utilized for standard slides. This may corrode in some applications. Stainless steel corrosion resistant shafting is available.

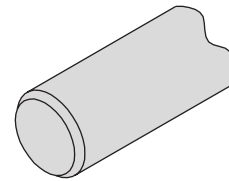

Side Porting (S)

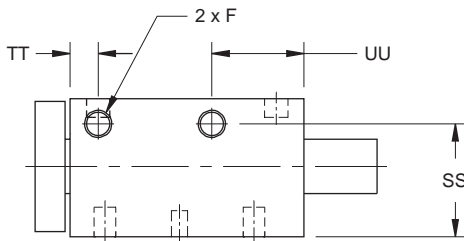

NOTES:

- Side ports not available on 100mm bore units with 25mm of stroke.
- Cannot use flow controls with 25mm stroke on any bore size.

Model	SS mm (in)	TT mm (in)	UU mm (in)	F
16	24.1 (.95)	10 (.39)	20 (.79)	10-32 or M5
20	29.00 (1.15)	10 (.39)	20 (.79)	10-32 or M5
25	35.15 (1.38)	11.4 (.45)	24 (.94)	10-32 or M5
32	43.2 (1.70)	10.35 (.41)	34 (1.34)	1/8 NPTF or BSPP
40	43.0 (1.69)	14.9 (.59)	34 (1.34)	1/8 NPTF or BSPP
50	51.25 (2.02)	16.1 (.64)	38 (1.50)	1/4 NPTF or BSPP
63	60.70 (2.39)	15.55 (.61)	41.8 (1.65)	1/4 NPTF or BSPP
80	75.5 (2.97)	19 (.75)	47 (1.85)	3/8 NPTF or BSPP
100	83.7 (3.30)	23 (.91)	53.3 (2.10)	3/8 NPTF or BSPP

Options

Flow Controls (B, F, N, P)

Right angle flow control valves allow precise adjustment of cylinder speed by metering exhaust air flow. Prestolok push-in or threaded ports provide 360° orientation capability.

Model	A (in)	B (in)	C (in)	Imperial	
				Prestolok (F)	NPT (N)
16, 20*, 25*	0.87	0.96	0.39	5/32"	10-32
20, 25, 32, 40	1.63	1.38	0.67	5/32"	1/8
50, 63	1.86	1.64	0.91	1/4"	1/4
80, 100	2.15	1.90	1.06	3/8"	3/8

Model	A (mm)	B (mm)	C (mm)	Metric	
				Prestolok (P)	BSPP (B)
16, 20*, 25*	22.0	24.5	10.0	4mm	M5
20, 25, 32, 40	34.5	31.6	14.4	6mm	1/8
50	41.0	34.9	18.4	6mm	1/4
63	41.0	41.3	18.4	10mm	1/4
80	51.0	46.7	21.6	10mm	3/8
100	51.0	46.7	21.6	12mm	3/8

* Side ports only.

Note: When flow controls are specified with rear ports, a 90° right angle fitting is supplied to provide ample rod clearance in the rear.

Prestolok flow controls are not available on 32-100mm bore sizes with 25mm of stroke.

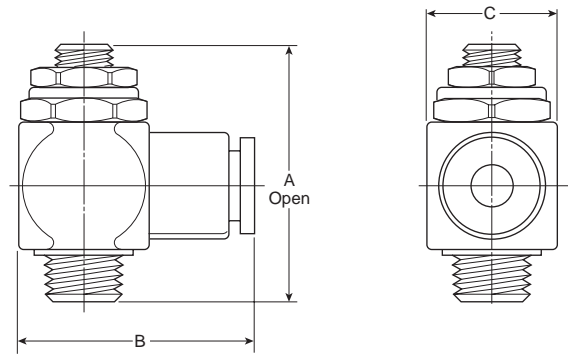

Fluorocarbon Seals (F)

Standard abrasion resistant nitrile seals should be used for general purpose applications with temperatures of -18 to 74°C (0 to 165°F). Fluorocarbon seals are recommended for high temperature applications up to 121°C (250°F).

Feature	Temperature Range
Bumpers	-18 to 93°C (0 to 200°F)
Magnets	-18 to 74°C (0 to 165°F)
Sensors	-10 to 85°C (14 to 185°F)

Standard Length – No Options (N),

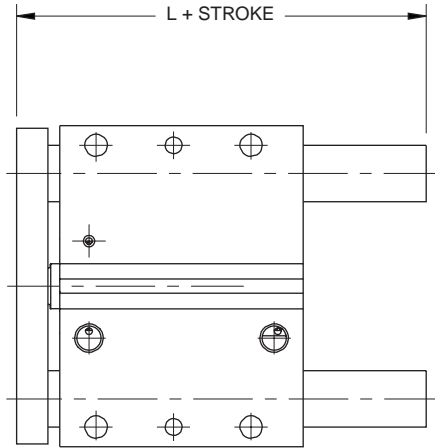

Model	Stroke (mm)	L	
		mm	inch
16	10*, 25, 40, 50, 75	60.2	2.37
	100	75.2	2.96
20	25, 40, 50, 75	66.9	2.63
	100, 125	91.9	3.62
25	25, 50, 75	69.9	2.75
	100, 125, 150	91.9	3.62
32	25, 50, 75, 100	77.9	3.07
	125, 150, 175, 200	116.0	4.57
40	25, 50, 75, 100	77.9	3.07
	125, 150, 175, 200	116.0	4.57
50	25, 50, 75, 100	84.0	3.31
	125, 150, 175, 200	124.1	4.89
63	25, 50, 75, 100	84.0	3.31
	125, 150, 175, 200	124.1	4.89
80	25, 50, 75, 100	101.8	4.00
	125, 150, 175, 200	140.0	5.51
100	25**, 50, 75, 100	120.3	4.74
	125, 150, 175, 200	158.4	6.24

* For Model 16 with 10mm stroke, L = 37.7 mm (1.48").

** For Model 100 with 25mm stroke, L = 122.8mm (4.8").

F

High Load Bearings (B)

The standard bearing configuration locates both sets of bearings at the tooling plate end of the actuator providing a compact actuator package. The high load bearings option (B) locates the bearings at the extreme ends of the housing, increasing the dynamic and static load capacity. The bearing centerlines increase as stroke length increases.

Note: Rear mounting and ports are not available with the high load bearing option.

Standard Bearings

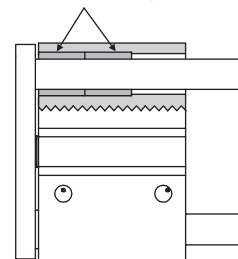

High Load Bearings

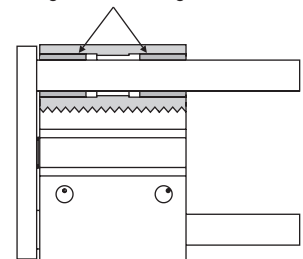

Dimensions

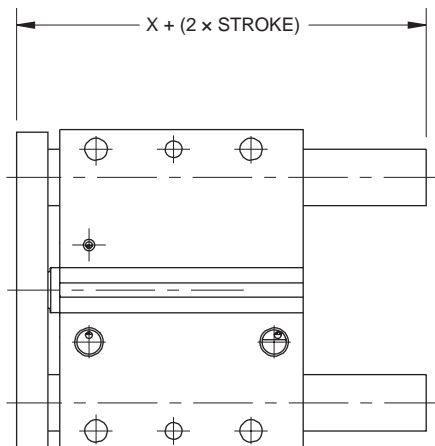

Model	X	
	mm	inch
16	49.7	1.955
20	47.0	1.849
25	49.9	1.963
32	51.1	2.012
40	59.1	2.327
50	61.6	2.425
63	66.8	2.630
80	79.6	3.135
100	86.1	3.391

Dual Tool Plate (D)

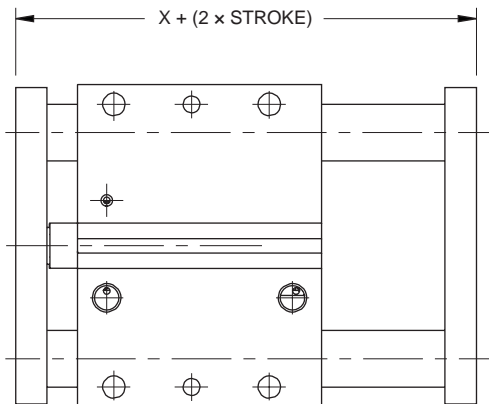

Notes:

1. Load capacities increase on dual tool plate (D & A). For load capacities, use the high load bearing graphs.
2. Rear mounting holes and rear ports are not available with Options D, A, and E.

Bumpers, Stop Collars & Dual Tool Plate (A)

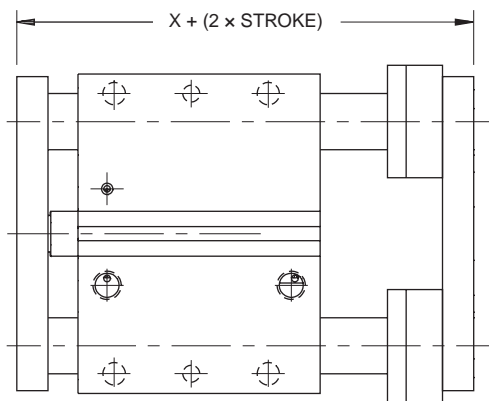

Bumpers & Adjustable Stop Collars, Extend Only (E)

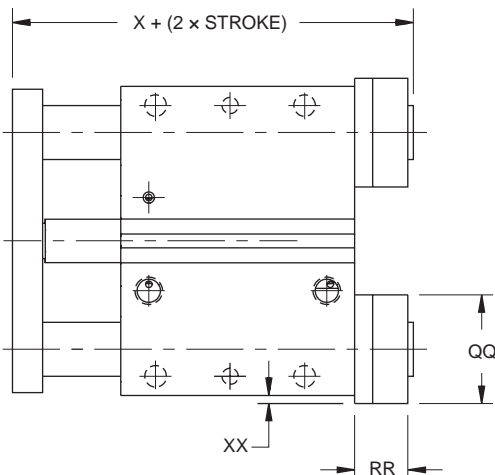

All dimensions in mm (inch)

Model	Rod Dia.	X			QQ	RR	XX
		D option	A option	E option			
16	8	57.7 (2.27)	70.7 (2.78)	62.7 (2.47)	18.0 (0.71)	15.7 (0.62)	0
	10	57.7 (2.27)	70.7 (2.78)	62.7 (2.47)	24.0 (0.95)	15.7 (0.62)	1 (0.04)
20	10	54.7 (2.15)	67.9 (2.67)	59.9 (2.36)	24.0 (0.95)	15.7 (0.62)	1 (0.04)
	12	54.7 (2.15)	72.6 (2.86)	64.6 (2.54)	28.0 (1.10)	17.7 (0.70)	3 (0.12)
25	12	58.8 (2.31)	76.5 (3.01)	68.1 (2.68)	28.0 (1.10)	17.7 (0.70)	1 (0.04)
	16	58.8 (2.31)	78.5 (3.09)	70.1 (2.76)	34.0 (1.34)	19.7 (0.78)	4 (0.16)
32	16	62.2 (2.45)	81.9 (3.22)	70.8 (2.79)	34.0 (1.34)	19.7 (0.78)	0
	20	62.2 (2.45)	83.9 (3.30)	72.8 (2.87)	40.0 (1.57)	21.7 (0.85)	3.7 (0.15)
40	16	70.2 (2.76)	89.9 (3.54)	78.8 (3.10)	34.0 (1.34)	19.7 (0.78)	0
	20	70.2 (2.76)	91.9 (3.62)	80.8 (3.18)	41.4 (1.63)	21.7 (0.85)	3.7 (0.15)
50	20	74.3 (2.93)	96.0 (3.78)	83.3 (3.28)	41.4 (1.63)	21.7 (0.85)	0.7 (0.03)
	25	74.3 (2.93)	96.0 (3.78)	83.3 (3.28)	45.0 (1.77)	21.7 (0.85)	5.4 (0.21)
63	20	79.5 (3.13)	101.2 (3.98)	88.5 (3.48)	41.4 (1.63)	21.7 (0.85)	0.7 (0.03)
	25	79.5 (3.13)	101.2 (3.98)	88.5 (3.48)	50.8 (2.00)	21.7 (0.85)	5.4 (0.21)
80	25	96.1 (3.78)	117.8 (4.64)	101.9 (4.01)	50.8 (2.00)	21.7 (0.85)	1.4 (0.06)
	30	96.1 (3.78)	117.8 (4.64)	101.9 (4.01)	54.0 (2.13)	21.7 (0.85)	6.3 (0.25)
100	30	103.3 (4.07)	125.8 (4.95)	109.1 (4.30)	60.5 (2.38)	21.7 (0.85)	3.3 (0.13)
	35	103.3 (4.07)	125.8 (4.95)	109.1 (4.30)	57.0 (2.24)	21.7 (0.85)	5.5 (0.22)



Contaminant & Weld Flash Covers

A contaminant cover protects the guide rods and bearings from particles and fluid that could cause premature failure.

A weld flash cover protects guide rods and bearings from weld spatter.

Cover option can be ordered on models having the bearings both ends option.

Consult factory to order.

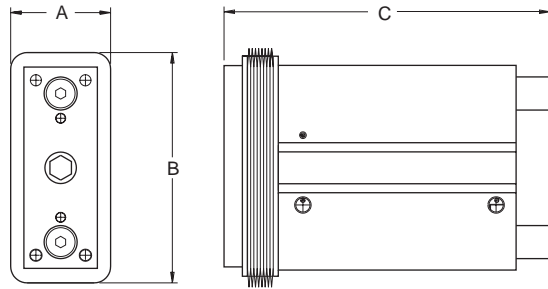

Weld Flash Cover Specifications

- Coating Material (exposed side)..... PVC (Black)
- Base Material Nomex
- Coating Material (other side)..... PVC (Black)
- Material Thickness Range012" - .016" (.3-4mm)
- Temperature Resistance (Nomex)
 - Briefly..... 642°F (450°C)
 - Continuously..... -22° to 572°F (-30° to 300°C)
- Temperature Resistance (Coating)
 - Briefly..... 392°F (200°C)
 - Continuously..... -22° to 302°F (-30° to 150°C)
- Resistant to..... Chemicals, coolants, solvents, oil
- Characteristics..... self-extinguishing, abrasion resistant
- Material Weight..... 400 grams/square meter

F

Dimensions

MODEL	A	B	10	25	40	50	75	100	125	150	175	200
16	42 (1.65)	86 (3.39)	61.2 (2.41)	100.2 (3.94)	135.2 (5.32)	135.2 (5.32)	160.2 (6.31)	200.2 (7.88)	-	-	-	-
20	45 (1.77)	98 (3.86)	-	106.9 (4.21)	141.9 (5.59)	141.9 (5.59)	166.9 (6.57)	216.9 (8.54)	241.9 (9.52)	-	-	-
25	49 (1.93)	112 (4.41)	-	119.9 (4.72)	-	144.9 (5.70)	169.9 (6.69)	194.9 (7.67)	241.9 (9.52)	266.9 (10.51)	-	-
32	62 (2.44)	142 (5.59)	-	127.9 (5.04)	-	152.9 (6.02)	177.9 (7.00)	202.9 (7.99)	266 (10.47)	291 (11.46)	316 (12.44)	341 (13.43)
40	62 (2.44)	152 (5.98)	-	127.9 (5.04)	-	152.9 (6.02)	177.9 (7.00)	202.9 (7.99)	266 (10.47)	291 (11.46)	316 (12.44)	341 (13.43)
50	66 (2.60)	167 (6.57)	-	134 (5.28)	-	159 (6.26)	184 (7.24)	209 (8.23)	274.1 (10.79)	299.1 (11.78)	324.1 (12.76)	349.1 (13.74)
63	77 (3.03)	187 (7.36)	-	134 (5.28)	-	159 (6.26)	184 (7.24)	209 (8.23)	274.1 (10.79)	299.1 (11.78)	324.1 (12.76)	349.1 (13.74)
80	104 (4.09)	244 (9.61)	-	151.8 (5.98)	-	176.8 (6.96)	201.8 (7.94)	226.8 (8.93)	290 (11.42)	315 (12.40)	340 (13.39)	365 (14.37)
100	109 (4.29)	279 (10.98)	-	170.3 (6.70)	-	195.3 (7.69)	220.3 (8.67)	245.3 (9.66)	308.4 (12.14)	333.4 (13.13)	358.4 (14.11)	383.4 (15.09)

All dimensions in mm (inch)

Reed and Solid State Sensors

Sensors are available in both short and standard configurations. Both styles mount in the sensor grooves on the P5T body. The standard sensors mount flush to the body. The short sensor extends out 4.5mm to the cable.

Both styles are available with quick connector or flying leads.

Magnetic piston is standard.

See Electronic Sensors section for part numbers and specifications.

Slide-in Short Sensor

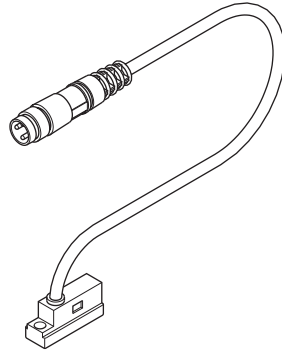

Drop-in Sensor

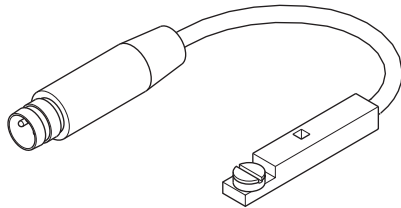

P5T

P5T2

P5TT/TD

P5L

HB

P5E

Seal Kits

Bore Size	Seal Kit Part Number	
	Nitrile Seals	Fluorocarbon Seals
16	PSK-P5T16	PSK-P5T16-F
20	PSK-P5T20	PSK-P5T20-F
25	PSK-P5T25	PSK-P5T25-F
32	PSK-P5T32	PSK-P5T32-F
40	PSK-P5T40	PSK-P5T40-F
50	PSK-P5T50	PSK-P5T50-F
63	PSK-P5T63	PSK-P5T63-F
80	PSK-P5T80	PSK-P5T80-F
100	PSK-P5T100	PSK-P5T100-F

F

Safety Guide for Selecting and Using Hydraulic, Pneumatic Cylinders and Their Accessories

WARNING: ⚠ FAILURE OF THE CYLINDER, ITS PARTS, ITS MOUNTING, ITS CONNECTIONS TO OTHER OBJECTS, OR ITS CONTROLS CAN RESULT IN:

- Unanticipated or uncontrolled movement of the cylinder or objects connected to it.
- Falling of the cylinder or objects held up by it.
- Fluid escaping from the cylinder, potentially at high velocity.

THESE EVENTS COULD CAUSE DEATH OR PERSONAL INJURY BY, FOR EXAMPLE, PERSONS FALLING FROM HIGH LOCATIONS, BEING CRUSHED OR STRUCK BY HEAVY OR FAST MOVING OBJECTS, BEING PUSHED INTO DANGEROUS EQUIPMENT OR SITUATIONS, OR SLIPPING ON ESCAPED FLUID.

Before selecting or using Parker (The Company) cylinders or related accessories, it is important that you read, understand and follow the following safety information. Training is advised before selecting and using The Company's products.

1.0 General Instructions

1.1 Scope – This safety guide provides instructions for selecting and using (including assembling, installing, and maintaining) cylinder products. This safety guide is a supplement to and is to be used with the specific Company publications for the specific cylinder products that are being considered for use.

1.2 Fail Safe – Cylinder products can and do fail without warning for many reasons. All systems and equipment should be designed in a fail-safe mode so that if the failure of a cylinder product occurs people and property won't be endangered.

1.3 Distribution – Provide a free copy of this safety guide to each person responsible for selecting or using cylinder products. Do not select or use The Company's cylinders without thoroughly reading and understanding this safety guide as well as the specific Company publications for the products considered or selected.

1.4 User Responsibility – Due to very wide variety of cylinder applications and cylinder operating conditions, The Company does not warrant that any particular cylinder is suitable for any specific application. This safety guide does not analyze all technical parameters that must be considered in selecting a product. The hydraulic and pneumatic cylinders outlined in this catalog are designed to The Company's design guidelines and do not necessarily meet the design guideline of other agencies such as American Bureau of Shipping, ASME Pressure Vessel Code etc. The user, through its own analysis and testing, is solely responsible for:

- Making the final selection of the cylinders and related accessories.
- Determining if the cylinders are required to meet specific design requirements as required by the Agency(s) or industry standards covering the design of the user's equipment.
- Assuring that the user's requirements are met, OSHA requirements are met, and safety guidelines from the applicable agencies such as but not limited to ANSI are followed and that the use presents no health or safety hazards.
- Providing all appropriate health and safety warnings on the equipment on which the cylinders are used.

1.5 Additional Questions – Call the appropriate Company technical service department if you have any questions or require any additional information. See the Company publication for the product being considered or used, or call 1-800-CPARKER, or go to www.parker.com, for telephone numbers of the appropriate technical service department.

2.0 Cylinder and Accessories Selection

2.1 Seals – Part of the process of selecting a cylinder is the selection of seal compounds. Before making this selection, consult the "seal information page(s)" of the publication for the series of cylinders of interest.

The application of cylinders may allow fluids such as cutting fluids, wash down fluids etc. to come in contact with the external area of the cylinder. These fluids may attack the piston rod wiper and or the primary seal and must be taken into account when selecting and specifying seal compounds.

Dynamic seals will wear. The rate of wear will depend on many operating factors. Wear can be rapid if a cylinder is mis-aligned or if the cylinder has been improperly serviced. The user must take seal wear into consideration in the application of cylinders.

2.2 Piston Rods – Possible consequences of piston rod failure or separation of the piston rod from the piston include, but are not limited to are:

- Piston rod and or attached load thrown off at high speed.
- High velocity fluid discharge.
- Piston rod extending when pressure is applied in the piston retract mode.

Piston rods or machine members attached to the piston rod may move suddenly and without warning as a consequence of other conditions occurring to the machine such as, but not limited to:

- Unexpected detachment of the machine member from the piston rod.
- Failure of the pressurized fluid delivery system (hoses, fittings, valves, pumps, compressors) which maintain cylinder position.
- Catastrophic cylinder seal failure leading to sudden loss of pressurized fluid.
- Failure of the machine control system.

Follow the recommendations of the "Piston Rod Selection Chart and Data" in the publication for the series of cylinders of interest. The suggested piston rod diameter in these charts must be followed in order to avoid piston rod buckling.

Piston rods are not normally designed to absorb bending moments or loads which are perpendicular to the axis of piston rod motion. These additional loads can cause the piston rod to fail. If these types of additional loads are expected to be imposed on the piston rod, their magnitude should be made known to our engineering department.

The cylinder user should always make sure that the piston rod is securely attached to the machine member.

On occasion cylinders are ordered with double rods (a piston rod extended from both ends of the cylinder). In some cases a stop is threaded on to one of the piston rods and used as an external stroke adjuster. On occasions spacers are attached to the machine member connected to the piston rod and also used as a stroke adjuster. In both cases the stops will create a pinch point and the user should consider appropriate use of guards. If these external stops are not perpendicular to the mating contact surface, or if debris is trapped between the contact surfaces, a bending moment will be placed on the piston rod, which can lead to piston rod failure. An external stop will also negate the effect of cushioning and will subject the piston rod to impact loading. Those two (2) conditions can cause piston rod failure. Internal stroke adjusters are available with and without cushions. The use of external stroke adjusters should be reviewed with our engineering department.

The piston rod to piston and the stud to piston rod threaded connections are secured with an anaerobic adhesive. The strength of the adhesive decreases with increasing temperature. Cylinders which can be exposed to temperatures above +250°F (+121°C) are to be ordered with a non studded piston rod and a pinned piston to rod joint.

2.3 Cushions – Cushions should be considered for cylinder applications when the piston velocity is expected to be over 4 inches/second.

Cylinder cushions are normally designed to absorb the energy of a linear applied load. A rotating mass has considerably more energy than the same mass moving in a linear mode. Cushioning for a rotating mass application should be review by our engineering department.

2.4 Cylinder Mountings – Some cylinder mounting configurations may have certain limitations such as but not limited to minimum stroke for side or foot mounting cylinders or pressure de-ratings for certain mounts. Carefully review the catalog for these types of restrictions.

Always mount cylinders using the largest possible high tensile alloy steel socket head cap screws that can fit in the cylinder mounting holes and torque them to the manufacturer's recommendations for their size.

2.5 Port Fittings – Hydraulic cylinders applied with meter out or deceleration circuits are subject to intensified pressure at piston rod end. The rod end pressure is approximately equal to:

$$\frac{\text{operating pressure} \times \text{effective cap end area}}{\text{effective rod end piston area}}$$

Contact your connector supplier for the pressure rating of individual connectors.

3.0 Cylinder and Accessories Installation and Mounting

3.1 Installation

3.1.1 – Cleanliness is an important consideration, and cylinders are shipped with the ports plugged to protect them from contaminants entering the ports. These plugs should not be removed until the piping is to be installed. Before making the connection to the cylinder ports, piping should be thoroughly cleaned to remove all chips or burrs which might have resulted from threading or flaring operations.

3.1.2 – Cylinders operating in an environment where air drying materials are present such as fast-drying chemicals, paint, or weld splatter, or other hazardous conditions such as excessive heat, should have shields installed to prevent damage to the piston rod and piston rod seals.

3.1.3 – Proper alignment of the cylinder piston rod and its mating component on the machine should be checked in both the extended and retracted positions. Improper alignment will result in excessive rod gland and/or cylinder bore wear. On fixed mounting cylinders attaching the piston rod while the rod is retracted will help in achieving proper alignment.

3.1.4 – Sometimes it may be necessary to rotate the piston rod in order to thread the piston rod into the machine member. This operation must always be done with zero pressure being applied to either side of the piston. Failure to follow this procedure may result in loosening the piston to rod-threaded connection. In some rare cases the turning of the piston rod may rotate a threaded piston rod gland and loosen it from the cylinder head. Confirm that this condition is not occurring. If it does, re-tighten the piston rod gland firmly against the cylinder head.

For double rod cylinders it is also important that when attaching or detaching the piston rod from the machine member that the torque be applied to the piston rod end of the cylinder that is directly attaching to the machine member with the opposite end unrestrained. If the design of the machine is such that only the rod end of the cylinder opposite to where the rod attaches to the machine member can be rotated, consult the factory for further instructions.

3.2 Mounting Recommendations

3.2.1 – Always mount cylinders using the largest possible high tensile alloy steel socket head screws that can fit in the cylinder mounting holes and torque them to the manufacturer's recommendations for their size.

3.2.2 – Side-Mounted Cylinders – In addition to the mounting bolts, cylinders of this type should be equipped with thrust keys or dowel pins located so as to resist the major load.

3.2.3 – Tie Rod Mounting – Cylinders with tie rod mountings are recommended for applications where mounting space is limited. The standard tie rod extension is shown as BB in dimension tables. Longer or shorter extensions can be supplied. Nuts used for this mounting style should be torqued to the same value as the tie rods for that bore size.

3.2.4 – Flange Mount Cylinders – The controlled diameter of the rod gland extension on head end flange mount cylinders can be used as a pilot to locate the cylinders in relation to the machine. After alignment has been obtained, the flanges may be drilled for pins or dowels to prevent shifting.

3.2.5 – Trunnion Mountings – Cylinders require lubricated bearing blocks with minimum bearing clearances. Bearing blocks should be carefully aligned and rigidly mounted so the trunnions will not be subjected to bending moments. The rod end should also be pivoted with the pivot pin in line and parallel to axis of the trunnion pins.

3.2.6 – Clevis Mountings – Cylinders should be pivoted at both ends with centerline of pins parallel to each other. After cylinder is mounted, be sure to check to assure that the cylinder is free to swing through its working arc without interference from other machine parts.

4.0 Cylinder and Accessories Maintenance, Troubleshooting and Replacement

4.1 Storage – At times cylinders are delivered before a customer is ready to install them and must be stored for a period of time. When storage is required the following procedures are recommended.

4.1.1 – Store the cylinders in an indoor area which has a dry, clean and noncorrosive atmosphere. Take care to protect the cylinder from both internal corrosion and external damage.

4.1.2 – Whenever possible cylinders should be stored in a vertical position (piston rod up). This will minimize corrosion due to possible condensation which could occur inside the cylinder. This will also minimize seal damage.

4.1.3 – Port protector plugs should be left in the cylinder until the time of installation.

4.1.4 – If a cylinder is stored full of hydraulic fluid, expansion of the fluid due to temperature changes must be considered. Installing a check valve with free flow out of the cylinder is one method.

4.1.5 – When cylinders are mounted on equipment that is stored outside for extended periods, exposed unpainted surfaces, e.g. piston rod, must be coated with a rust-inhibiting compound to prevent corrosion.

4.2 Cylinder Trouble Shooting

4.2.1 – External Leakage

4.2.1.1 – Rod seal leakage can generally be traced to worn or

damaged seals. Examine the piston rod for dents, gouges or score marks, and replace piston rod if surface is rough.

Rod seal leakage could also be traced to gland wear. If clearance is excessive, replace rod bushing and seal. Rod seal leakage can also be traced to seal deterioration. If seals are soft or gummy or brittle, check compatibility of seal material with lubricant used if air cylinder, or operating fluid if hydraulic cylinder. Replace with seal material, which is compatible with these fluids. If the seals are hard or have lost elasticity, it is usually due to exposure to temperatures in excess of 165°F. (+74°C). Shield the cylinder from the heat source to limit temperature to 350°F. (+177°C.) and replace with fluorocarbon seals.

4.2.1.2 – Cylinder body seal leak can generally be traced to loose tie rods. Torque the tie rods to manufacturer's recommendation for that bore size.

Excessive pressure can also result in cylinder body seal leak. Determine maximum pressure to rated limits. Replace seals and retorque tie rods as in paragraph above. Excessive pressure can also result in cylinder body seal leak. Determine if the pressure rating of the cylinder has been exceeded. If so, bring the operating pressure down to the rating of the cylinder and have the tie rods replaced.

Pinched or extruded cylinder body seal will also result in a leak. Replace cylinder body seal and retorque as in paragraph above.

Cylinder body seal leakage due to loss of radial squeeze which shows up in the form of flat spots or due to wear on the O.D. or I.D. – Either of these are symptoms of normal wear due to high cycle rate or length of service. Replace seals as per paragraph above.

4.2.2 – Internal Leakage

4.2.2.1 – Piston seal leak (by-pass) 1 to 3 cubic inches per minute leakage is considered normal for piston ring construction. Virtually no static leak with lipseal type seals on piston should be expected. Piston seal wear is a usual cause of piston seal leakage. Replace seals as required.

4.2.2.2 – With lipseal type piston seals excessive back pressure due to over-adjustment of speed control valves could be a direct cause of rapid seal wear. Contamination in a hydraulic system can result in a scored cylinder bore, resulting in rapid seal wear. In either case, replace piston seals as required.

4.2.2.3 – What appears to be piston seal leak, evidenced by the fact that the cylinder drifts, is not always traceable to the piston. To make sure, it is suggested that one side of the cylinder piston be pressurized and the fluid line at the opposite port be disconnected. Observe leakage. If none is evident, seek the cause of cylinder drift in other component parts in the circuit.

4.2.3 – Cylinder Fails to Move the Load

4.2.3.1 – Pneumatic or hydraulic pressure is too low. Check the pressure at the cylinder to make sure it is to circuit requirements.

4.2.3.2 – Piston Seal Leak – Operate the valve to cycle the cylinder and observe fluid flow at valve exhaust ports at end of cylinder stroke. Replace piston seals if flow is excessive.

4.2.3.3 – Cylinder is undersized for the load – Replace cylinder with one of a larger bore size.

4.3 Erratic or Chatter Operation

4.3.1 – Excessive friction at rod gland or piston bearing due to load misalignment – Correct cylinder-to-load alignment.

4.3.2 – Cylinder sized too close to load requirements – Reduce load or install larger cylinder.

4.3.3 – Erratic operation could be traced to the difference between static and kinetic friction. Install speed control valves to provide a back pressure to control the stroke.

4.4 Cylinder Modifications, Repairs, or Failed Component – Cylinders as shipped from the factory are not to be disassembled and/or modified. If cylinders require modifications, these modifications must be done at company locations or by The Company's certified facilities. The Cylinder Division Engineering Department must be notified in the event of a mechanical fracture or permanent deformation of any cylinder component (excluding seals). This includes a broken piston rod, tie rod, mounting accessory or any other cylinder component. The notification should include all operation and application details. This information will be used to provide an engineered repair that will prevent recurrence of the failure.

It is allowed to disassemble cylinders for the purpose of replacing seals or seal assemblies. However, this work must be done by strictly following all the instructions provided with the seal kits.

Offer of Sale

The items described in this document and other documents or descriptions provided by Parker Hannifin Corporation, its subsidiaries and Divisions ("Company") and its authorized distributors, are hereby offered for sale at prices to be established by the Company, its subsidiaries and its authorized distributors. This offer and its acceptance by any customer ("Buyer") shall be governed by all of the following Terms and Conditions. Buyer's order for any such item, when communicated to the Company, its subsidiary or an authorized distributor ("Seller") verbally or in writing, shall constitute acceptance of this offer.

1. Terms and Conditions of Sale: All descriptions, quotations, proposals, offers, acknowledgments, acceptances and sales of Seller's products are subject to and shall be governed exclusively by the terms and conditions stated herein. Buyer's acceptance of any offer to sell is limited to these terms and conditions. Any terms or conditions in addition to, or inconsistent with those stated herein, proposed by Buyer in any acceptance of an offer by Seller, are hereby objected to. No such additional, different or inconsistent terms and conditions shall become part of the contract between Buyer and Seller unless expressly accepted in writing by Seller. Seller's acceptance of any offer to purchase by Buyer is expressly conditional upon Buyer's assent to all the terms and conditions stated herein, including any terms in addition to, or inconsistent with those contained in Buyer's offer. Acceptance of Seller's products shall in all events constitute such assent.

2. Payment: Payment shall be made by Buyer net 30 days from the date of delivery of the items purchased hereunder. Amounts not timely paid shall bear interest at the maximum rate permitted by law for each month or portion thereof that the Buyer is late in making payment. Any claims by Buyer for omissions or shortages in a shipment shall be waived unless Seller receives notice thereof within 30 days after Buyer's receipt of the shipment.

3. Delivery: Unless otherwise provided on the face hereof, delivery shall be made F.O.B. Seller's plant. Regardless of the method of delivery, however, risk of loss shall pass to Buyer upon Seller's delivery to a carrier. Any delivery dates shown are approximate only and Seller shall have no liability for any delays in delivery.

4. Warranty: Seller warrants that the items sold hereunder shall be free from defects in material or workmanship for a period of 18 months from date of shipment from the Company. **THIS WARRANTY COMPRISES THE SOLE AND ENTIRE WARRANTY PERTAINING TO ITEMS PROVIDED HEREUNDER. SELLER MAKES NO OTHER WARRANTY, GUARANTEE, OR REPRESENTATION OF ANY KIND WHATSOEVER. ALL OTHER WARRANTIES, INCLUDING BUT NOT LIMITED TO, MERCHANTABILITY AND FITNESS FOR PURPOSE, WHETHER EXPRESS, IMPLIED, OR ARISING BY OPERATION OF LAW, TRADE USAGE, OR COURSE OF DEALING ARE HEREBY DISCLAIMED.**

NOTWITHSTANDING THE FOREGOING, THERE ARE NOWARRANTIES WHATSOEVER ON ITEMS BUILT OR ACQUIRED WHOLLY OR PARTIALLY, TO BUYER'S DESIGN OR SPECIFICATIONS.

5. Limitation of Remedy: SELLER'S LIABILITY ARISING FROM OR IN ANY WAY CONNECTED WITH THE ITEMS SOLD OR THIS CONTRACT SHALL BE LIMITED EXCLUSIVELY TO REPAIR OR REPLACEMENT OF THE ITEMS SOLD OR REFUND OF THE PURCHASE PRICE PAID BY BUYER, AT SELLER'S SOLE OPTION. IN NO EVENT SHALL SELLER BE LIABLE FOR ANY INCIDENTAL, CONSEQUENTIAL OR SPECIAL DAMAGES OF ANY KIND OR NATURE WHATSOEVER, INCLUDING BUT NOT LIMITED TO LOST PROFITS ARISING FROM OR IN ANY WAY CONNECTED WITH THIS AGREEMENT OR ITEMS SOLD HEREUNDER, WHETHER ALLEGED TO ARISE FROM BREACH OF CONTRACT, EXPRESS OR IMPLIED WARRANTY, OR IN TORT, INCLUDING WITHOUT LIMITATION, NEGLIGENCE, FAILURE TO WARN OR STRICT LIABILITY.

6. Changes, Reschedules and Cancellations: Buyer may request to modify the designs or specifications for the items sold hereunder as well as the quantities and delivery dates thereof, or may request to cancel all or part of this order, however, no such requested modification or cancellation shall become part of the contract between Buyer and Seller unless accepted by Seller in a written amendment to this Agreement. Acceptance of any such requested modification or cancellation shall be at Seller's discretion, and shall be upon such terms and conditions as Seller may require.

7. Special Tooling: A tooling charge may be imposed for any special tooling, including without limitations, dies, fixtures, molds and patterns, acquired to manufacture items sold pursuant to this contract. Such special tooling shall be and remain Seller's property notwithstanding payment of any charges by Buyer. In no event will Buyer acquire any interest in apparatus belonging to Seller which is utilized in the manufacture of the items sold hereunder, even if such apparatus has been specially converted or adapted for such manufacture and notwithstanding any charges paid by Buyer. Unless otherwise agreed, Seller shall have the right to alter,

discard or otherwise dispose of any special tooling or other property in its sole discretion at any time.

8. Buyer's Property: Any designs, tools, patterns, materials, drawings, confidential information or equipment furnished by Buyer, or any other items which become Buyer's property, may be considered obsolete and may be destroyed by Seller after two (2) consecutive years have elapsed without Buyer placing an order for the items which are manufactured using such property. Seller shall not be responsible for any loss or damage to such property while it is in Seller's possession or control.

9. Taxes: Unless otherwise indicated on the face hereof, all prices and charges are exclusive of excise, sales, use, property, occupational or like taxes which may be imposed by any taxing authority upon the manufacture, sale or delivery of the items sold hereunder. If any such taxes must be paid by Seller or if Seller is liable for the collection of such tax, the amount thereof shall be in addition to the amounts for the items sold. Buyer agrees to pay all such taxes or to reimburse Seller therefore upon receipt of its invoice. If Buyer claims exemption from any sales, use or other tax imposed by any taxing authority, Buyer shall save Seller harmless from and against any such tax, together with any interest or penalties thereon which may be assessed if the items are held to be taxable.

10. Indemnity For Infringement of Intellectual Property Rights: Seller shall have no liability for infringement of any patents, trademarks, copyrights, trade dress, trade secrets or similar rights except as provided in this Part 10. Seller will defend and indemnify Buyer against allegations of infringement of U.S. patents, U.S. trademarks, copyrights, trade dress and trade secrets (hereinafter "Intellectual Property Rights"). Seller will defend at its expense and will pay the cost of any settlement or damages awarded in an action brought against Buyer based on an allegation that an item sold pursuant to this contract infringes the Intellectual Property Rights of a third party. Seller's obligation to defend and indemnify Buyer is contingent on Buyer notifying Seller within ten (10) days after Buyer becomes aware of such allegations of infringement, and Seller having sole control over the defense of any allegations or actions including all negotiations for settlement or compromise. If an item sold hereunder is subject to a claim that it infringes the Intellectual Property Rights of a third party, Seller may, at its sole expense and option, procure for Buyer the right to continue using said item, replace or modify said item so as to make it noninfringing, or offer to accept return of said item and return the purchase price less a reasonable allowance for depreciation. Notwithstanding the foregoing, Seller shall have no liability for claims of infringement based on information provided by Buyer, or directed to items delivered hereunder for which the designs are specified in whole or part by Buyer, or infringements resulting from the modification, combination or use in a system of any item sold hereunder. The foregoing provisions of this Part 10 shall constitute Seller's sole and exclusive liability and Buyer's sole and exclusive remedy for infringement of Intellectual Property Rights.

If a claim is based on information provided by Buyer or if the design for an item delivered hereunder is specified in whole or in part by Buyer, Buyer shall defend and indemnify Seller for all costs, expenses or judgments resulting from any claim that such item infringes any patent, trademark, copyright, trade dress, trade secret or any similar right.

11. Force Majeure: Seller does not assume the risk of and shall not be liable for delay or failure to perform any of Seller's obligations by reason of circumstances beyond the reasonable control of Seller (hereinafter "Events of Force Majeure"). Events of Force Majeure shall include without limitation, accidents, acts of God, strikes or labor disputes, acts, laws, rules or regulations of any government or government agency, fires, floods, delays or failures in delivery of carriers or suppliers, shortages of materials and any other cause beyond Seller's control.

12. Entire Agreement/Governing Law: The terms and conditions set forth herein, together with any amendments, modifications and any different terms or conditions expressly accepted by Seller in writing, shall constitute the entire Agreement concerning the items sold, and there are no oral or other representations or agreements which pertain thereto. This Agreement shall be governed in all respects by the law of the State of Ohio. No actions arising out of sale of the items sold hereunder or this Agreement may be brought by either party more than two (2) years after the cause of action accrues.