



Inline Pulse-Tone™

Hydraulic Shock Suppressors

Inline Pulse-Tone™ Shock Suppressors Feature:

- Three Bladder Polymers for a Wide Range of Fluids and Temperatures
- NPT, BSPP, SAE or Split Flange Connections
- Mounting in Any Position
- 3000 PSI Models for Water/Chemical Service



The Patented **PULSE-TONE™** Construction

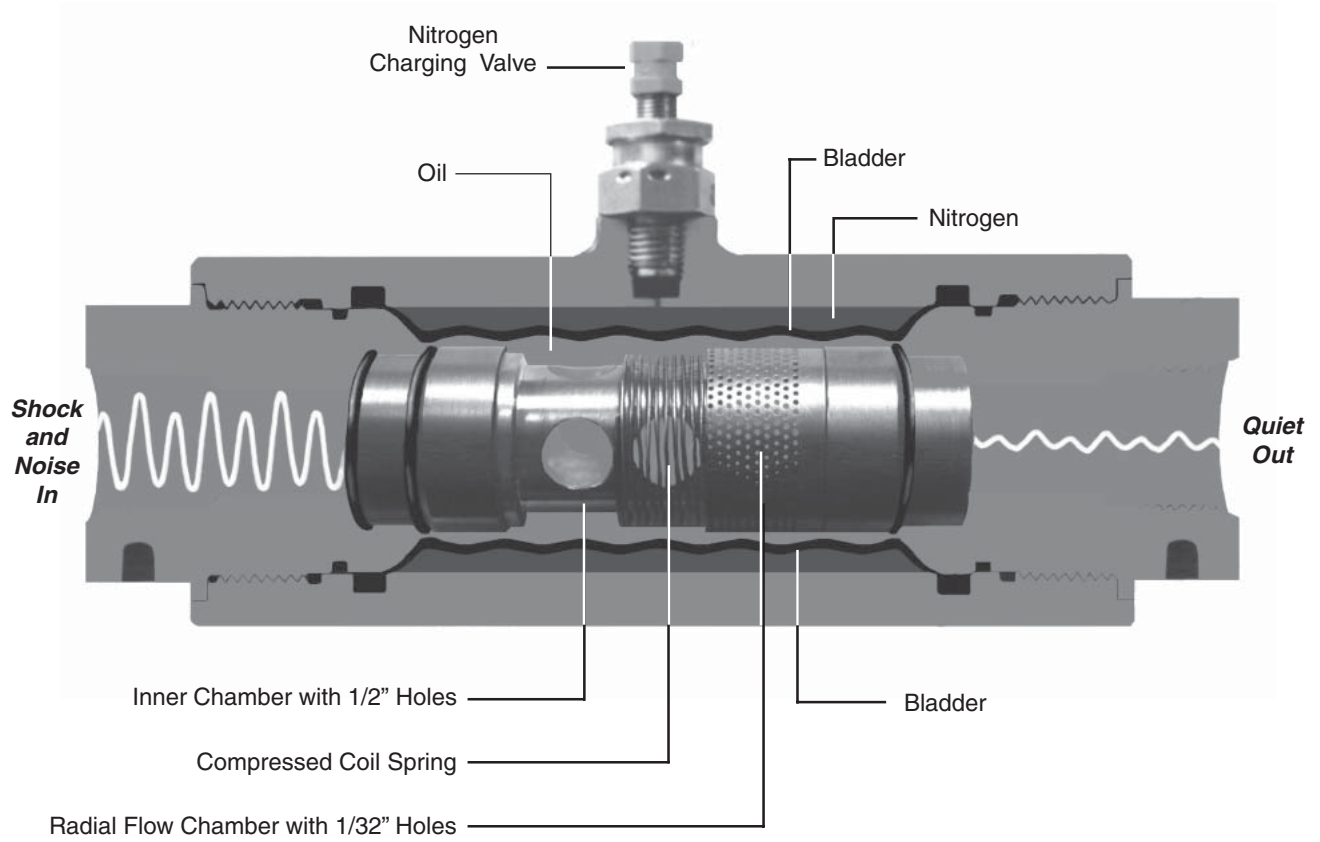

Why Should You Use the **PULSE-TONE** Shock Suppressor?

Noise pollution is the hottest topic in the hydraulic industry today. Lab tests show that pump noise levels are increased by 2-3 dB(A) just by adding 12 feet of outlet and return lines. The lines do not generate noise. They radiate noise when they respond to pulsations or vibrations. The pulsations are usually generated by the pump, and the vibrations are radiated by large flat machine surfaces.

Not only do hydraulic lines radiate noise, but they frequently provide the primary path for propagating noise from the pump to components that, in turn, react to the noise and radiate additional sound. This helps explain why many pump manufacturers have a very low dB(A) pump rating, but when the pump is installed on a power unit, the sound rating is much higher.

It is almost impossible to forecast how much additional sound the hydraulic lines and surrounding structure will radiate. This is why many power units are enclosed after they have been manufactured and installed.

The Inline Pulse-Tone reduces pump pulsations and shock. When you stop pulsation and vibration, you stop the cause of component wear and leakage. A power unit with an Inline Pulse-Tone installed can operate at higher RPM with smaller, less expensive components . . . and less noise.

NOTE OF INTEREST: An increase of 2.71 dB doubles the intensity noise level.

How Does the **PULSE-TONE** Work?

An Inline Pulse-Tone suppressor is located as close to the pump as possible, usually directly at the pump outlet, to stop pulsations and noise before they travel through the piping and radiate off other structural components.

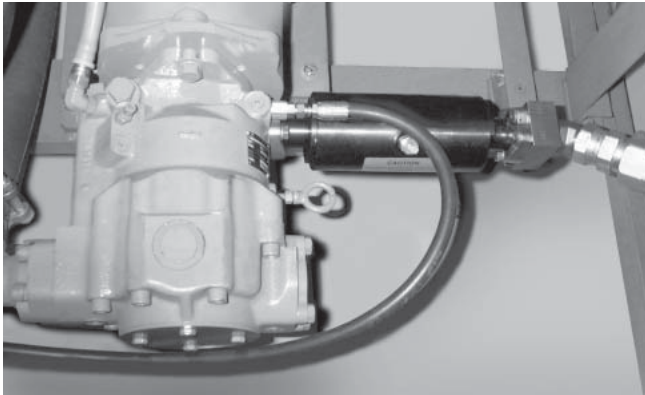

As shown in the diagram on the facing page, oil flowing into the Pulse-Tone goes through three different baffles or diffusers. These metal baffles are designed to convert 1/2" diameter holes to 1/32" diameter holes. The total radial distance through these baffles is only 1/4".

After passing through these holes, pulsations strike a nitrogen charged rubber bladder. The bladder deflects each time it is hit by a pulsation. This slight deflection of the bladder reduces the shock and noise.

The bladder is usually charged with nitrogen to 50% to 60% of the hydraulic operating pressure. The 1/32" diameter holes in the last baffle are so small that the bladder cannot extrude into them.

The large area of the bladder, its ability to oscillate at a high frequency and the short distance each pulsation has to travel once it enters the unit explain the effectiveness of the Pulse-Tone.

Selecting a **PULSE-TONE** is Easy!

No complex sizing formula is required. The Inline Pulse-Tone hydraulic shock suppressor is sized to match your hydraulic line size. There is a unit to fit

every pipe and tube size from 3/8" to 2" with threaded or flanged connections. Models are available for both 3000 PSI and 5000 PSI hydraulic system pressures.



Features	Advantages	Benefits
Reduces pulsations and shock	Less component wear and system leakage	Less maintenance
Reduces noise	Better work environment Eliminates need for sound proofing Use smaller, higher RPM components Smaller motor starters	Higher worker morale and productivity Lower system costs Design flexibility
No moving mechanical parts	Nothing to break	Low maintenance costs
Wide range of port sizes	Accommodates both hose and tube sizes	Ease of installation
Flange mountings	Allows for installation of larger units	Mounting ease and flexibility
Unit is bidirectional.	Cannot be installed backwards	Ease of installation
Compact size	Allows for mounting close to pump	Easily added to existing power units
Special materials for water or chemical service	Resists corrosion	Longer life and wider variety of applications
Can be supplied with customer specified precharge	Ease and speed of adjusting to system parameters	Shorter installation time
Short delivery times	Eliminates customer inventory	Lower operating costs

Models

- 3000 psi rated for oil applications
- 3000 psi Stainless Steel for water and chemical applications
- 5000 psi for high pressure oil applications

Port Connections

Four types of hydraulic line connections are available:

- NPT pipe connections from 3/8" to 2" pipe
- BSPP connections from 3/8" to 2" pipe
- SAE port connection from 3/8" to 2" tubing
- Split flange connection from 3/4" to 3"

Inline Pulse-Tone units can be ordered with any combination of ends, such as a split flange one end and a straight thread on the opposite end. When ordering, specify the type of connection for each end.

Bladder Materials

- Standard material is high temperature HNBR, -50° to 300°F (-45° to 149°C)
- Fluorocarbon or EPR bladders are available for special applications

Precharge

The unit can be shipped with a nitrogen precharge equal to 50% of hydraulic system pressure. Check precharge every three months to maintain maximum efficiency. (See page 184 for procedures.)

Mounting

The Pulse-Tone may be mounted in any position, horizontal or vertical. Since there are no moving parts, either end may be used for inlet or outlet. Split flange mounting makes it possible to break an existing connection to add the Pulse-Tone between the flanges.

Examples of Pulsation Reduction

The examples below show pulsations for pumps at various pressures before and after installation of the Inline Pulse-Tone.

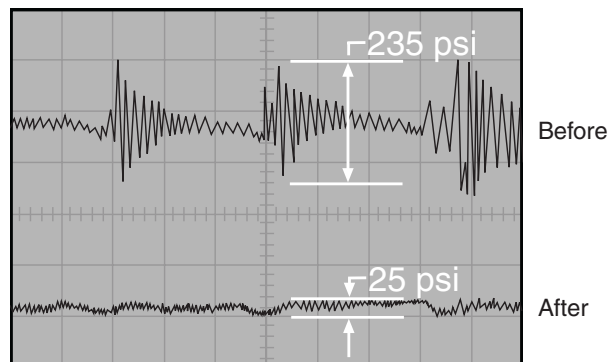

Piston Pump at 4000 psi and 1800 rpm

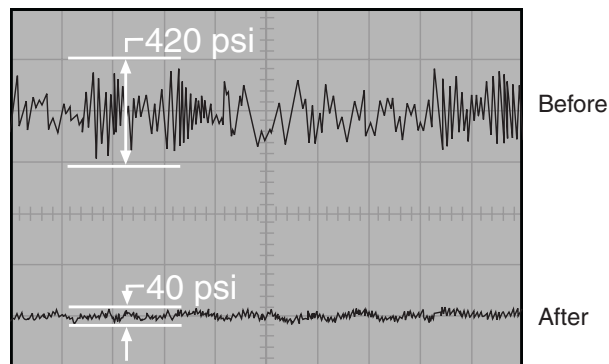

Piston Pump at 2000 psi and 1800 rpm

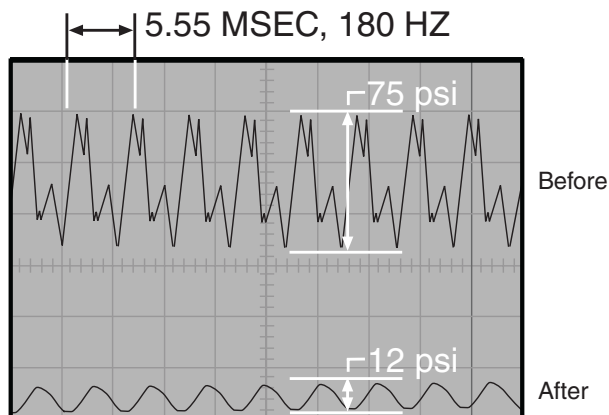

Piston Pump at 750 psi and 1200 rpm

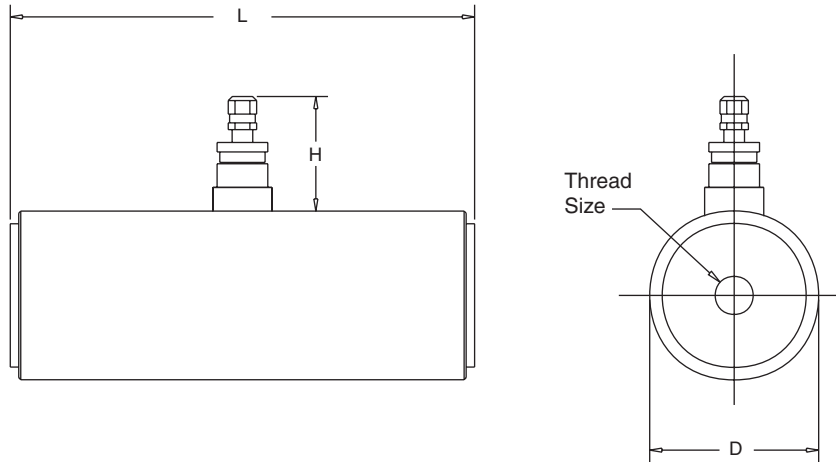

3000 PSI Pipe Thread Connections

Model	NPT Size	BSPP Size	Flow, GPM 15'/sec	Flow, GPM 20'/sec*	Dimensions, inch (mm)			Weight lbs. (kg)
					D	H	L	
PT250D1H	3/8 1/2	3/8 1/2	11.3	15.1	2.5 (63.5)	1.75 (44.5)	6.875 (174.6)	6.5 (3)
PT262D1H	3/4 1 —	3/4 1 1 1/4	24.2	32.1	2.625 (66.7)	1.75 (44.5)	8.13 (206.5)	8.0 (3.6)
PT400D1H	1 1 1/4 1 1/2	1 1 1/4 1 1/2	68.9	91.9	4.0 (101.6)	1.75 (44.5)	8.875 (225.4)	24.5 (11.1)
PT475D1H	1 1/2 2	1 1/2 2	128.0	171.0	4.75 (120.7)	1.75 (44.5)	10.5 (266.7)	31 (14.1)

3000 PSI Straight Thread Connections

Model	Tube Size	Thread	Flow, GPM 15'/sec	Flow, GPM 20'/sec*	Dimensions, inch (mm)			Weight lbs. (kg)
					D	H	L	
PT250D1H	.375 .500 .625	9/16-18 3/4-16 7/8-14	11.3	15.1	2.5 (63.5)	1.75 (44.5)	6.875 (174.6)	6.5 (3)
PT262D1H	.750 1.00 1.25	1-1/16-12 1-5/16-12 1-5/8-12	24.1	32.1	2.625 (66.7)	1.75 (44.5)	8.13 (206.5)	8 (3.6)
PT400D1H	1.00 1.25 1.50	1-5/16-12 1-5/8-12 1-7/8-12	68.9	91.9	4.0 (101.6)	1.75 (44.5)	8.875 (225.4)	24.5 (11.1)
PT475D1H	2.00	2-1/2-12	128.0	171.0	4.75 (120.7)	1.75 (44.5)	10.5 (266.7)	31 (14.1)

* Pressure drop in the suppressor is equal to pressure drop in 8" of tubing. Flow rates can be at least 50% higher than those listed for 20'/sec. without excessive pressure drop.

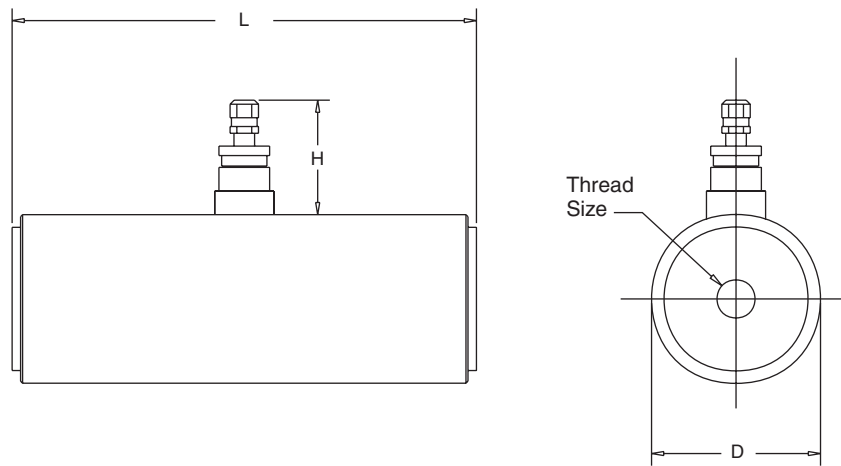
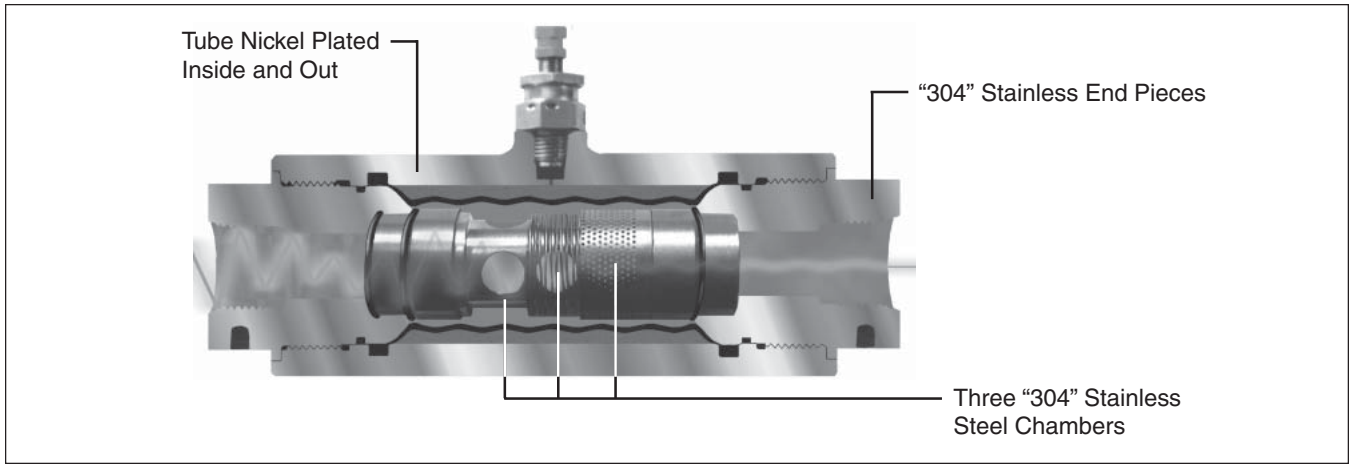

3000 PSI Pipe Thread Connections

Model	NPT Size	Flow, GPM 15'/sec	Flow, GPM 20'/sec*	Dimensions, inch (mm)			Weight lbs. (kg)
				D	H	L	
PT262D3H	3/4"	24.2	32.1	2.625 (66.7)	1.75 (44.5)	8.13 (206.5)	8.0 (3.6)
	1"						
PT400D3H	1"	68.9	91.9	4.0 (101.6)	1.75 (44.5)	8.875 (225.4)	24.5 (11.1)
	1 1/4"						
	1 1/2"						

3000 PSI Straight Thread Connections

Model	Tube Size	Thread	Flow, GPM 15'/sec	Flow, GPM 20'/sec*	Dimensions, inch (mm)			Weight lbs. (kg)
					D	H	L	
PT262D3H	.750	1-1/16-12	24.1	32.1	2.625 (66.7)	1.75 (44.5)	8.13 (206.5)	8 (3.6)
	1.00	1-5/16-12						
	1.25	1-5/8-12						
PT400D3H	1.00	1-5/16-12	68.9	91.9	4.0 (101.6)	1.75 (44.5)	8.875 (225.4)	24.5 (11.1)
	1.25	1-5/8-12						
	1.50	1-7/8-12						

* Pressure drop in the suppressor is equal to pressure drop in 8" of tubing. Flow rates can be at least 50% higher than those listed for 20'/sec. without excessive pressure drop.

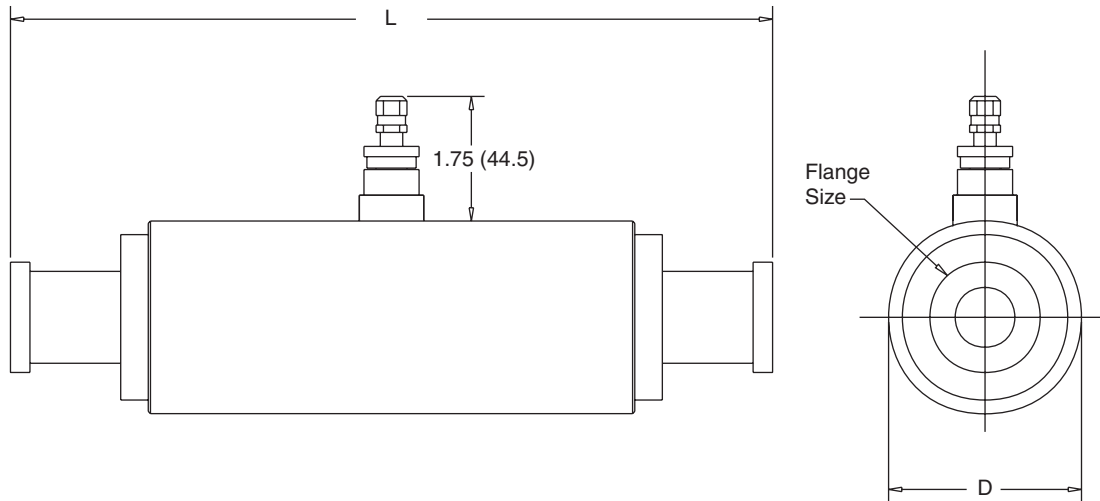

3000 PSI for Code 61 Flange Mounting

Model	Flange Size	D	Code 61 Flange					Code 62 Flange*				
			A	B	L	E	F	A	B	L	E	F
PT262D1HP	0.75	2.625 (66.7)	1.75 (44.5)	.56 (14.2)	10.12 (257.0)	1.875 (47.6)	0.875 (22.2)	2.000 (50.8)	.75 (19.1)	10.620 (269.7)	2.000 (50.8)	0.938 (23.8)
	1.00	2.625 (66.7)	1.75 (44.5)	.62 (15.7)	10.12 (257.0)	2.062 (52.4)	1.030 (26.2)	2.000 (50.8)	.94 (23.9)	10.620 (269.7)	2.250 (57.1)	1.094 (27.8)
	1.25	2.625 (66.7)	2.00 (50.8)	.56 (14.2)	10.62 (269.7)	2.312 (58.7)	1.188 (30.2)	2.250 (57.1)	1.06 (26.9)	11.120 (282.4)	2.625 (66.7)	1.250 (31.8)
PT400D1HP	1.25	4.00 (101.6)	2.25 (57.1)	.56 (14.2)	13.12 (333.2)	2.312 (58.7)	1.188 (30.2)	2.250 (57.1)	1.06 (26.9)	13.125 (333.4)	2.625 (66.7)	1.250 (31.8)
	1.50	4.00 (101.6)	2.25 (57.1)	.62 (15.7)	13.12 (333.2)	2.750 (69.9)	1.406 (35.7)	2.250 (57.1)	1.19 (30.2)	13.625 (346.1)	3.125 (79.4)	1.438 (36.5)
	2.00	4.00 (101.6)	2.38 (60.4)	.62 (15.7)	13.38 (339.9)	3.062 (77.8)	1.688 (42.9)	2.620 (66.5)	1.44 (36.6)	13.875 (352.4)	3.812 (96.8)	1.750 (44.5)
PT475D1HP	2.00	4.75 (120.6)	2.38 (60.4)	.62 (15.7)	15.00 (381.0)	3.062 (77.8)	1.688 (42.9)	2.620 (66.5)	1.44 (36.6)	13.875 (352.4)	3.812 (96.8)	1.750 (44.5)
	2.50**	4.75 (120.6)	2.875 (73.0)	.75 (19.0)	16.00 (406.4)	3.500 (88.9)	2.000 (50.8)	—	—	—	—	—
	3.00***	4.75 (120.6)	3.25 (82.6)	.88 (22.3)	16.75 (425.4)	4.188 (106.4)	2.438 (61.9)	—	—	—	—	—

* When using Code 62 flanges, do not exceed 3000 psi pressure rating of the unit.

** Maximum pressure rating for this flange is 2500 psi.

*** Maximum pressure rating for this flange is 2000 psi.

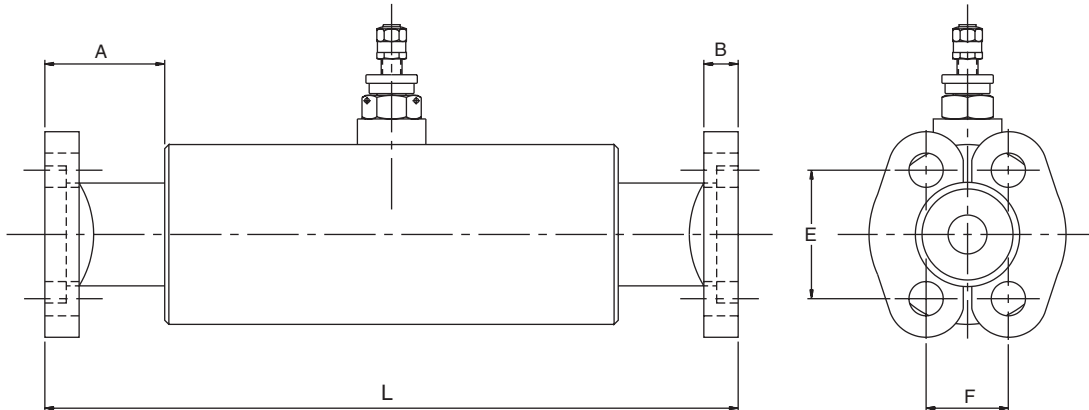

Ordering Note

The Pulse-Tone flange mounted unit is not supplied with split flanges.

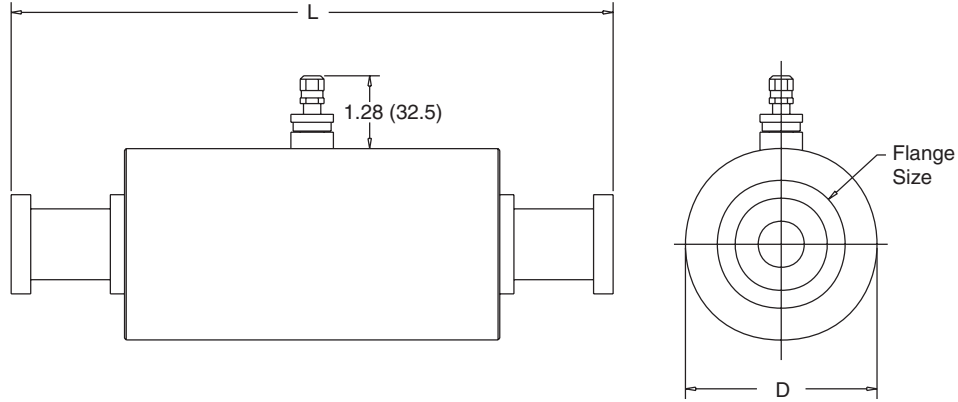

5000 PSI for Flange Mounting

Model Number	Flange Size	Code 62 Flange* Dimensions, inch (mm)					
		A	B	D	L	E	F
PT338C1HP	1.00	2.000 (50.8)	.94 (23.9)	3.38 (85.8)	10.620 (269.7)	2.250 (57.2)	1.094 (27.8)
	1.25	2.250 (57.2)	1.06 (26.9)	3.38 (85.8)	11.120 (282.4)	2.625 (66.7)	1.250 (31.8)
PT500C1HP	1.25	2.250 (57.2)	1.06 (26.9)	5.00 (127.0)	13.125 (333.4)	2.625 (66.7)	1.250 (31.8)
	1.50	2.500 (63.5)	1.19 (30.2)	5.00 (127.0)	13.625 (346.1)	3.125 (79.4)	1.438 (36.5)
	2.00	2.620 (66.5)	1.44 (35.6)	5.00 (127.0)	13.875 (352.4)	3.812 (96.8)	1.750 (44.5)

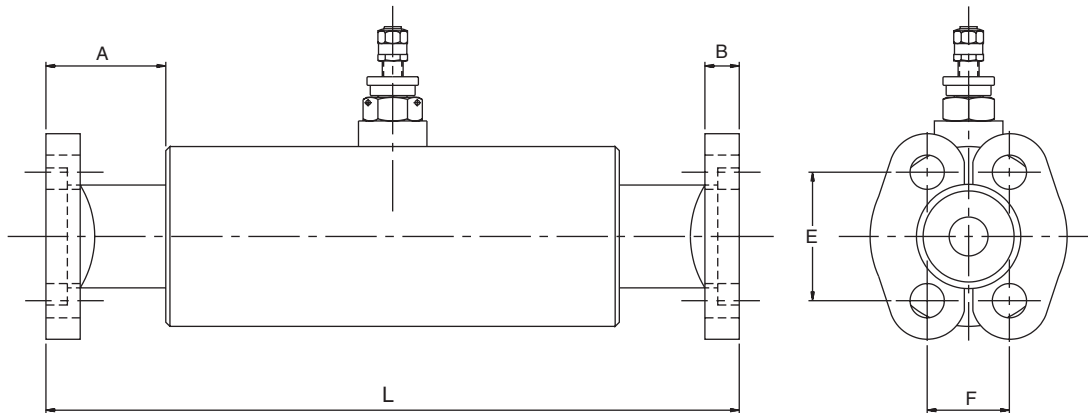

Ordering Note

The Pulse-Tone flange mounted unit is not supplied with split flanges.

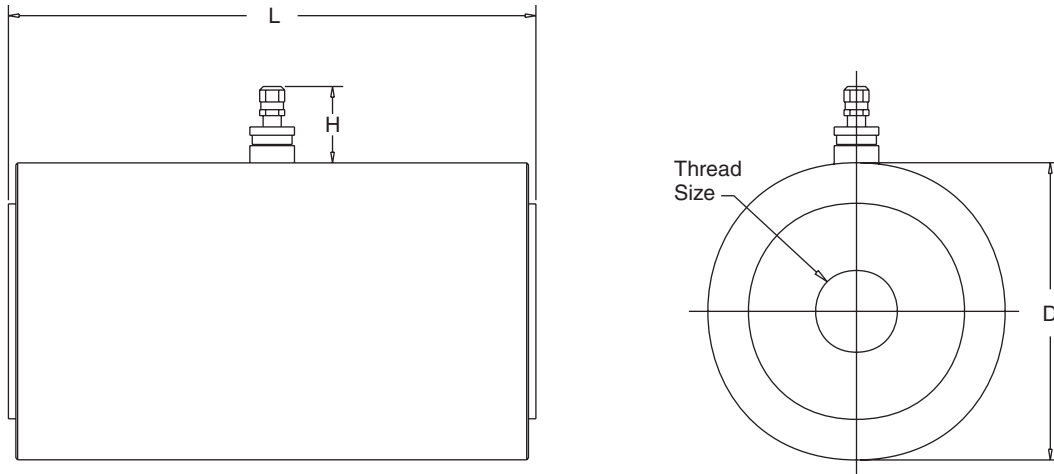

5000 PSI Straight Thread Connections

Model	For Tube Suppressor	Thread In Rate	Maximum Flow	Dimensions, inch (mm)			Weight lbs. (kg)
				D	H	L	
PT338C1H	.750	1-1/16-12	49 GPM	3.38 (85.8)	1.28 (32.5)	8.13 (206.5)	15 (6.36)
	1.00	1-5/16-12					
	1.25	1-5/8-12					
PT500C1H	1.00	1-5/16-12	150 GPM	5.0 (127.0)	1.28 (32.5)	8.88 (225.6)	48 (21.8)
	1.25	1-5/8-12					
	1.50	1-7/8-12					

* Pressure drop in unit is equal to pressure drop of 8" of tubing. Flow rates can be at least 50% higher than those listed for 20'/sec without excessive pressure drop.

Repair Kits

Repair kits include a bladder and o-rings. Order by series and seal material.

Series	HNBR	EPR	Fluorocarbon
250	RKPT2500H0	RKPT2500D0	RKPT2500E0
262 & 338	RKPT2620H0	RKPT2620D0	RKPT2620E0
400 & 500	RKPT4000H0	RKPT4000D0	RKPT4000E0
475	RKPT4750H0	RKPT4750D0	RKPT4750E0

How to Order

Use the symbols in the chart below to develop an Inline Pulse-Tone model number. Select only those symbols that represent the features desired and place them in the sequence indicated by the example at the top of the chart.

Series PT	Size 250	Pressure D	Design 1	Seals H	Hydraulic Ports*		Precharge Pressure*
					Type —	Size —	Type —
					Type —	Size —	Precharge Pressure* —

3000 PSI Sizes		Pressure		Seals		Precharge Pressure*	
250	2.50" Dia.	D	3000 PSI	D	EPR*	If desired, indicate pressure in psi. If not desired, leave blank. * Provided at additional cost.	
262	2.625" Dia.	C	5000 PSI	E	Fluorocarbon		
400	4.00" Dia.			H	HNBR (STD)		
5000 PSI Sizes							
338	3.375" Dia.						
500	5.00" Dia.						

Design	
1	Standard
3	Water/Chem Service*
S	Special

* Available in Sizes 262 and 400 only.

Port Type	Port Size
T SAE	B SAE #6 (9/16-18)
	C SAE #8 (3/4-16)
	I SAE #10 (7/8-14)
	D SAE #12 (1-1/16-12)
	E SAE #16 (1-5/16-12)
	F SAE #20 (1-5/8-12)
	G SAE #24 (1-7/8-12)
	H SAE #32 (2-1/2-12)
U NPT	T 3/8"
	U 1/2"
	V 3/4"
	W 1"
	X 1 1/4"
	Y 1 1/2"
	Z 2"
	R BSPP Parallel
B 1/2"	
C 3/4"	
D 1"	
E 1 1/4"	
F 1 1/2"	
G 2"	
P Code 61** Split Flange	
	V 1"
	W 1 1/4"
	J 1 1/2"
	L 2"
	M 2 1/2"
	N 3"
	P Code 62** Split Flange
G 1"	
H 1 1/4"	
P 1 1/2"	
Q 2"	

Port Availability

Size	SAE							
	#6	#8	#10	#12	#16	#20	#24	#32
250	●	●	●					
262				■	■	■		
400					■	■	■	
475								●
338			●	●	●			
500				●	●	●		

Size	NPT/BSPP							
	3/8	1/2	3/4	1	1 1/4	1 1/2	2	
250	●	●						
262			■	■	▲			
400				■	■	■		
475							●	●
338			▲	▲	▲			
500				▲	▲	▲		

- ▲ BSPP only
- Available for Water/Chemical Service

Flange Availability

Size	Code 61							
	3/4	1	1 1/4	1 1/2	2	2 1/2	3	
262	●	●	●					
400			●	●	●			
475					●	◆	◆	

Size	Code 62				
	3/4	1	1 1/4	1 1/2	2
338	●	●	●		
500			●	●	●

- ◆ Maximum pressure rating for the 2 1/2" flange is 2500 PSI. Maximum pressure rating for the 3" flange is 2000 PSI.

* Different type and size hydraulic ports may be ordered for each end. Specify left hand port first if ports are not the same.

**When ordering different flange port sizes, specify port that connects to the pump first.

Charging & Gauging Assemblies

Includes 10 ft. charging hose with standard right-hand thread nitrogen fittings, adapter incorporating gas valve, bleeder valve and gas chuck and gauge.



Charging & Gauging Assemblies are sold in plastic carrying case.

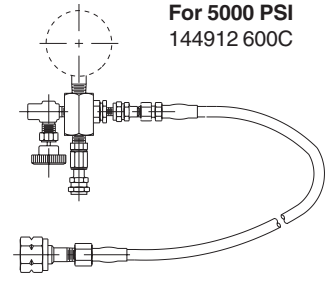
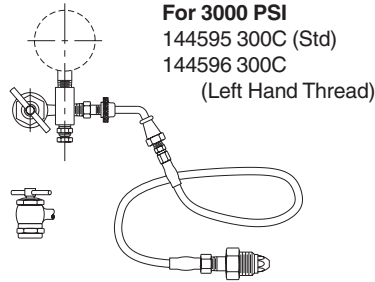

Gauges

Gauges may be ordered separately. Listed below are 2½" dial type pressure gauges with 100 PSI graduation. Include blowout safety case and orifice surge damper.

Part Number	Pressure Range
087040 1000	0 - 1000 PSI
087040 2000	0 - 2000 PSI
087040 3000	0 - 3000 PSI
087040 4000	0 - 4000 PSI
087040 5000	0 - 5000 PSI
087040 6000	0 - 6000 PSI

Mounting Clamps

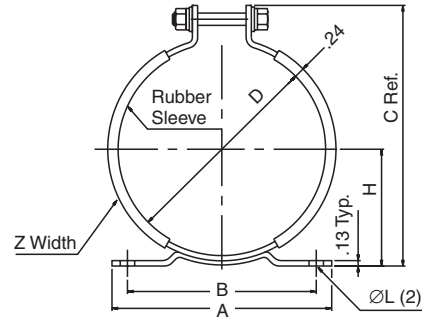

Clamp Dimensions

Series	Part No.	Dimensions, inch (mm)						
		A	B	C	D	H	ØL	Z
252	8700110252	4.25 (107.9)	3.35 (85.1)	4.42 (112.3)	2.62/2.82 (66.5/71.6)	1.64 (41.7)	0.37 x 0.50 (9.4 x 12.7)	1.25 (31.8)
338	8700110358	5.00 (127)	3.94 (100.1)	5.62 (142.7)	3.25/3.50 (82.6/88.9)	2.28 (57.9)	0.37 x 0.50 (9.4 x 12.7)	1.25 (31.8)
400	8700110413	5.25 (133.4)	4.33 (109.2)	6.06 (153.9)	3.84/4.11 (97.5/104.1)	2.45 (62.2)	0.37 x 0.50 (9.4 x 12.7)	1.25 (31.8)
475	8700110476	5.25 (133.4)	4.33 (109.2)	6.71 (170.4)	4.67/4.90 (118.6/124.5)	2.77 (70.3)	0.37 x 0.50 (9.4 x 12.7)	1.25 (31.8)
500	8700110535	5.75 (146.1)	4.92 (125.0)	7.43 (188.7)	5.02/5.32 (127.5/135.1)	3.21 (81.5)	0.37 x 0.50 (9.4 x 12.7)	1.25 (31.8)

