



aerospace
climate control
electromechanical
filtration
fluid & gas handling
hydraulics
pneumatics
process control
sealing & shielding



Portable Filter Carts

Models 5MFP & 10MFP with Moduflow™ *Plus*



ENGINEERING YOUR SUCCESS.

Applications for Portable Filter Carts

- **Filtering new fluid before putting into service**
- **Transferring fluid from drums or storage tanks to system reservoirs**
- **Conditioning fluid that is already in use**
- **Complimenting existing system filtration**
- **Removing free water from a system**
- **For use with fluids such as hydraulic, gear and lube oils**

Parker portable filter carts are the ideal way to prefilter and transfer fluids into reservoirs or to clean up existing systems.

Fluid should always be filtered before being put into use. New fluid is not necessarily clean fluid. Most new fluids (right out of the drum) are unfit for use due to high initial contamination levels. Contamination, both particulate and water, may be added to a new fluid during processing, mixing, handling and storage.

Water is removed by installing Par-Gel™ elements in the outlet filter. Par-Gel™ elements are made from a polymer which has a very high affinity for free water.

Once water comes into contact with this material, it is removed from the system.

The Parker portable filter cart uses two high capacity ModuFlow™ Plus filters for long element life and better system protection. The first stage (inlet) filter captures larger particles, while the second stage (outlet) filter controls finer particles or removes water. A rugged industrial quality gear pump gets the job done fast.

Using a Parker portable filter cart is the most economical way to protect your system from the harm that can be caused by contamination.

| Features | Advantages | Benefits |
|---|---|--|
| <ul style="list-style-type: none"> • Two filters instead of one w/ 2.5 times increased DHC | <ul style="list-style-type: none"> • Pump protection and long element life | <ul style="list-style-type: none"> • Element cost savings and trouble-free service |
| <ul style="list-style-type: none"> • Wide variety of particulate elements available | <ul style="list-style-type: none"> • Capable of getting a fluid to a desired cleanliness level | <ul style="list-style-type: none"> • Extends fluid life and system performance |
| <ul style="list-style-type: none"> • Par-Gel™ water removal elements available | <ul style="list-style-type: none"> • Removes “free water” from a system | <ul style="list-style-type: none"> • Gets dirt and water out of system with one process |
| <ul style="list-style-type: none"> • Heavy duty frame | <ul style="list-style-type: none"> • Rugged and durable | <ul style="list-style-type: none"> • Built to last for many hours of use |
| <ul style="list-style-type: none"> • Lightweight and portable | <ul style="list-style-type: none"> • Easy to move from place-to-place | <ul style="list-style-type: none"> • One person operation |
| <ul style="list-style-type: none"> • Two flow rates available: 5 gpm or 10 gpm | <ul style="list-style-type: none"> • Enables use in low or high viscosity applications | <ul style="list-style-type: none"> • Matched to your needs |
| <ul style="list-style-type: none"> • Eleven-foot hose and wand assemblies included | <ul style="list-style-type: none"> • Additional hardware not necessary | <ul style="list-style-type: none"> • Ready to use as received |

Features

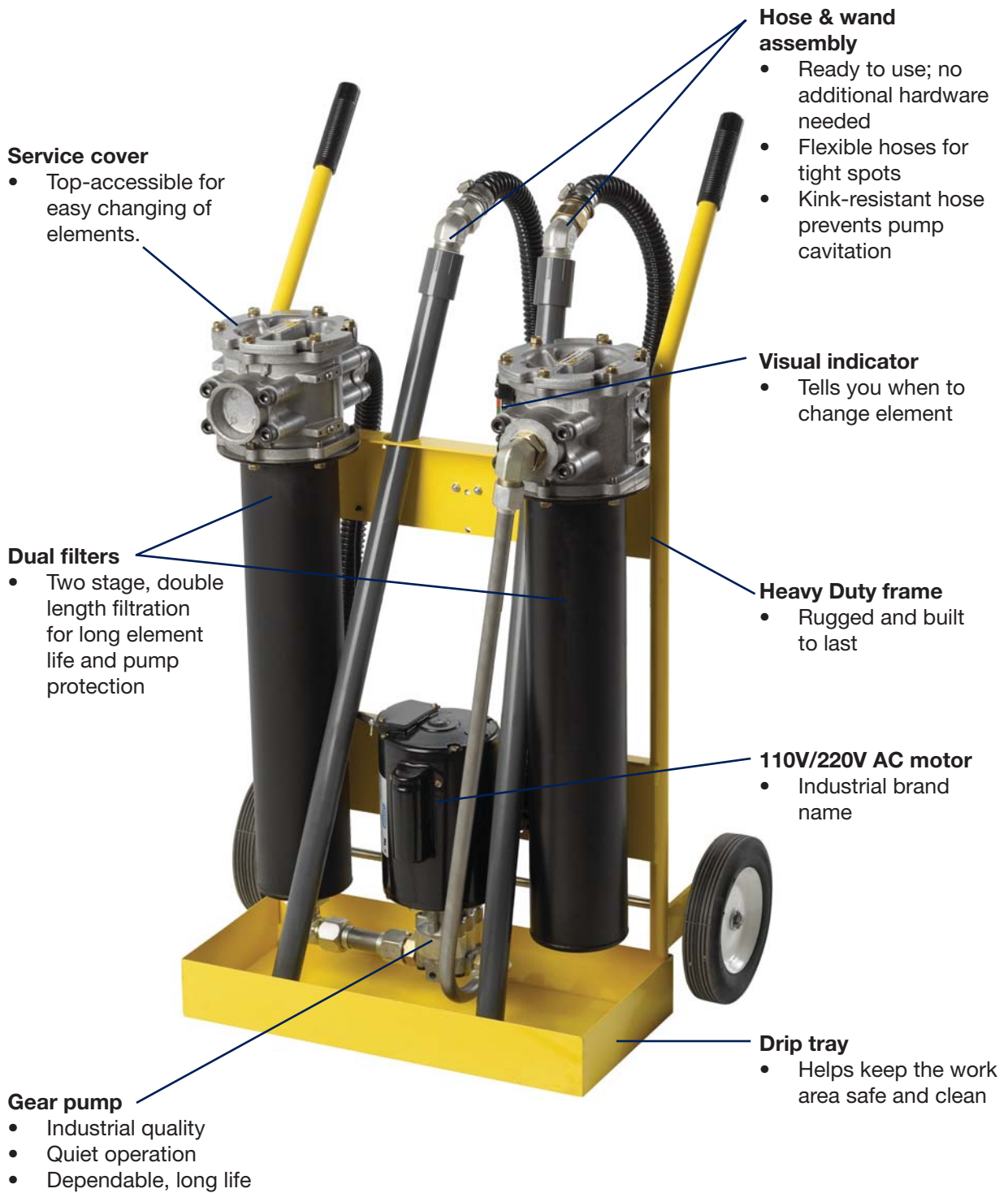

Service cover

- Top-accessible for easy changing of elements.

Hose & wand assembly

- Ready to use; no additional hardware needed
- Flexible hoses for tight spots
- Kink-resistant hose prevents pump cavitation

Visual indicator

- Tells you when to change element

Dual filters

- Two stage, double length filtration for long element life and pump protection

Heavy Duty frame

- Rugged and built to last

110V/220V AC motor

- Industrial brand name

Drip tray

- Helps keep the work area safe and clean

Gear pump

- Industrial quality
- Quiet operation
- Dependable, long life

Elements (not shown)

- Available for both particulate and Water Removal (WR) in double length w/ 2.5 times increased DHC

Electrical Cord (not shown)

- 6 ft. with ON/OFF switch
- Optional 20 ft. cord with retractable reel & mounted power switch with thermal overload protection

Specifications:

Maximum Recommended Fluid

Viscosity:

5MFP - 3000 SUS (627cSt)
0.85 specific gravity

10MFP - 500 SUS (108 cSt)
0.85 specific gravity

Visual Indicator (outlet filter):

Visual differential type
3-band (clean, change, bypass)

Filter Bypass Valve Settings (Integral to Element):

Inlet - 3 psid (0.2 bar)
Outlet - 35 psid (2.4 bar)

Operating Temperature:

Seal option "B" (standard)
-40°F to +150°F (-40°C to +66°C)

Seal option "V" (high temp option)
-15°F to +200°F (-26°C to +93°C)

Electrical Service Required:

5MFP - 110/220 volts, 60/50
Hz, single phase, 8/4 amps
10MFP - 110/220 volts, 60/50
Hz, single phase, 10/5 amps

Electrical Motor:

5MFP - ½ hp @ 1725 rpm,
O.D.P.
10MFP - ¾ hp @ 3450 rpm,
O.D.P.
Thermal overload protection

Construction:

Cart frame - Steel
Filter head - Aluminum
Filter bowl - Steel
Hoses - PVC (Std.)
EPDM (high temp option)
Wands - PVC (Std.)
Steel tube (high temp option)

Weight:

110 lbs. (45.4kg)

Dimensions:

A = Height: 1034mm (40.7 in.)

B = Width: 648mm (25.5 in.)

C = Depth: 503mm (19.8 in.)



Typical Fluid Cleanliness Level Requirements

Many manufacturers of hydraulic components have established fluid cleanliness levels for their components. Using a portable filter cart can be a very effective way to reach and maintain these cleanliness levels.

| Component | ISO Cleanliness Level |
|---|-----------------------|
| Servo control valves | 16/14/11 |
| Proportional valves | 17/15/12 |
| Vane and piston pumps/motors | 18/16/13 |
| Directional and pressure control valves | 18/16/13 |
| Gear pumps/motors | 19/17/14 |
| Flow control valves cylinders | 20/18/15 |
| New fluid | 20/18/15 |

Filter Cart Element Performance

| Media Code | Filter Media | Capacity (Grams) |
|------------|----------------|------------------|
| 40W | Woven Wire | * |
| 40SA | Synthetic | * |
| 20Q | Microglass III | 140 |
| 10Q | Microglass III | 135 |
| 05Q | Microglass III | 130 |
| 02Q | Microglass III | 110 |

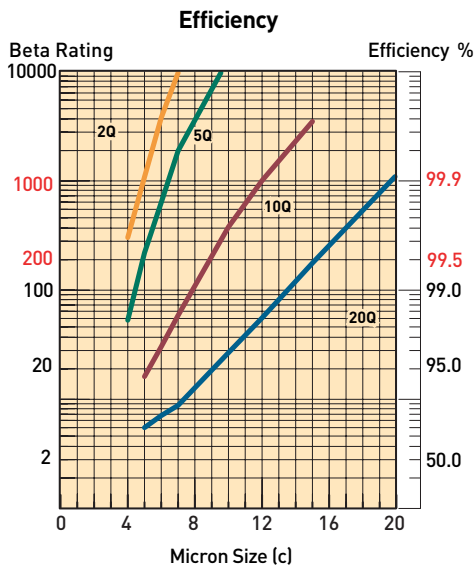

Notes: Multipass test run @ 80 gpm to 50 psid terminal - 5 mg/l BUGL.

Filter Cart Performance

Fluid cleanliness levels are a function of initial contamination levels, contamination ingress rates, reservoir size and filter element efficiency. The chart below lists approximate time requirements to achieve certain cleanliness levels based on the assumptions noted.

| Reservoir Capacity (Gallons) | Time Required (Hours) | Projected Cleanliness Level (ISO) |
|------------------------------|-----------------------|-----------------------------------|
| 50 | 0.5 | 20/18/15 |
| 50 | 1.0 | 17/15/12 |
| 50 | 2.5 | 16/14/11 |
| 100 | 1.5 | 18/16/13 |
| 100 | 2.5 | 17/15/12 |
| 100 | 4.0 | 16/14/11 |
| 200 | 2.5 | 19/17/14 |
| 200 | 3.5 | 18/16/13 |
| 200 | 5.0 | 17/15/12 |

Notes:

The results in the chart are based on the following assumption:

1. Initial contamination level is 500,000 particles greater than 10 micrometers per 100 ml of fluid (10MFP cart).
2. Inlet filter fitted with 40SA element; outlet with 20Q element.
3. System ingress rate equal to 1×10^6 particles greater than 10 micrometers entering the system per minute.

Par-Gel™ Media Water Capacity

| Model | Fluid Viscosity | Capacity |
|-------|-----------------|----------|
| 5MFP | 75 SUS | 600 ml |
| | 200 SUS | 420 ml |
| 10MFP | 75 SUS | 500 ml |
| | 200 SUS | 300 ml |

Notes:

1. Par-Gel™ elements are designed to remove “free water”, which is defined as water that is above a particular fluid’s saturation level.
2. Capacity is very dependent on flow rate and viscosity. Not recommended with fluids in excess of 500 SUS.

Assembly

1. Install hoses to inlet and outlet filters by threading the hose end with the straight thread o-ring seal fitting into the filter flange.
2. Connect the PVC tube wands to the swivel fitting on the hose end. When servicing the PVC tube wand, do not over-torque the metal fittings going into the PVC coupling. Over-torque will result in cracking the coupling. Generally, 1/4 turn beyond hand-tight is sufficient.

Operating Instructions

1. Insert the inlet wand assembly into the supply fluid receptacle (drum/reservoir). The RFP filter is the inlet filter.
2. Insert the outlet wand assembly into the clean fluid receptacle (drum/reservoir). The ILP filter is the outlet filter.

Caution: Do not kink the hose assemblies, this may result in excessive vacuum or pressure at the pump.

3. Verify that the ON/OFF switch is OFF and plug the cord into the proper grounded power source (3 wire).
4. Turn switch to ON position and check outlet wand for oil flow. Allow 30 to 60 seconds for filters to fill with oil. If repeated attempts to obtain oil flow fail, check pump inlet fittings for tightness, remove inlet filter access cover and verify the cover sealing o-ring is in place. For very viscous fluids it may be necessary to pour 1 or 2 quarts of fluid into the RFP inlet filter housing to prime pump initially.

5. The condition of the filter element should be monitored by observing the cleanliness indicator on the outlet filter. When the indicator is in the CHANGE position, both inlet and outlet filter elements MUST be replaced to prevent fluid from going through the bypass in the filters.
6. The inlet filter element is provided with a 3PSI bypass spring, and prevents the pump from cavitating if the element is not changed. The outlet filter element is provided with a 35PSI bypass spring to prevent excessive pressure which may be harmful to personnel or to the filter cart.

Warning: The filter bypass spring acts as a relief valve for the pump. Do not restrict the outlet hose with a shut-off valve which will defeat the function of the bypass valve, causing excessive pressure, which may be harmful to personnel or to the filter cart.

7. The cleanliness indicator works on differential pressure and will indicate the condition of the element (CLEAN, CHANGE, or BYPASS).

NOTE: The filter cart must be in operation for the indicator to read properly.

Maintenance Instructions

1. Turn switch to OFF position and unplug cord from electrical outlet.
2. Remove tube wands from oil to prevent siphoning.
3. Loosen hex head screws on filter cover. Turn cover to clear screws, remove cover.
4. Pull filter element from the filter head.
 - a) Replace the synthetic or Microglass III elements. Verify replacement.
 - b) Wire mesh elements can be cleaned. Ultrasonic cleaners provide best results.
5. Install element in filter housing. Make sure element o-rings seat properly into the head, making sure that the notch on the element lines up with the notch in the head.
6. Inspect the cover o-ring and replace if necessary.
7. Replace cover and tighten hex head screws until they are snug. Do not over-torque these screws. Do not interchange the inlet filter cover with the outlet filter cover. (The inlet filter has a "RFP" prefix, the outlet filter has a "ILP" prefix).

Trouble Shooting

| Problem | Cause | Solution |
|-----------------------------------|--|--|
| Does not start | ON/OFF Switch No electrical power Defective motor | Turn switch ON, replace switch if defective Plug in cart Replace |
| No oil flow or erratic pump noise | Filter housing not filled with oil Suction leak Defective pump | Allow pump to run 30 to 60 seconds Check tightness of inlet fittings Check o-ring in inlet filter cover for nicks Kink or restriction in inlet hose Add 1 or 2 quarts of oil to inlet filter Replace pump |
| Indicator reads CHANGE or BYPASS | Element dirty Oil extremely cold or viscous | Replace or clean elements (both filters) Change element to coarser micron rating |
| Indicator does not seem to move | No outlet element 40 micron element installed in outlet filter | Install element Check cart model number to verify correct element. The inlet filter has a rating RFP prefix; the outlet filter has an ILP prefix |

Filter Cart Replacement Parts

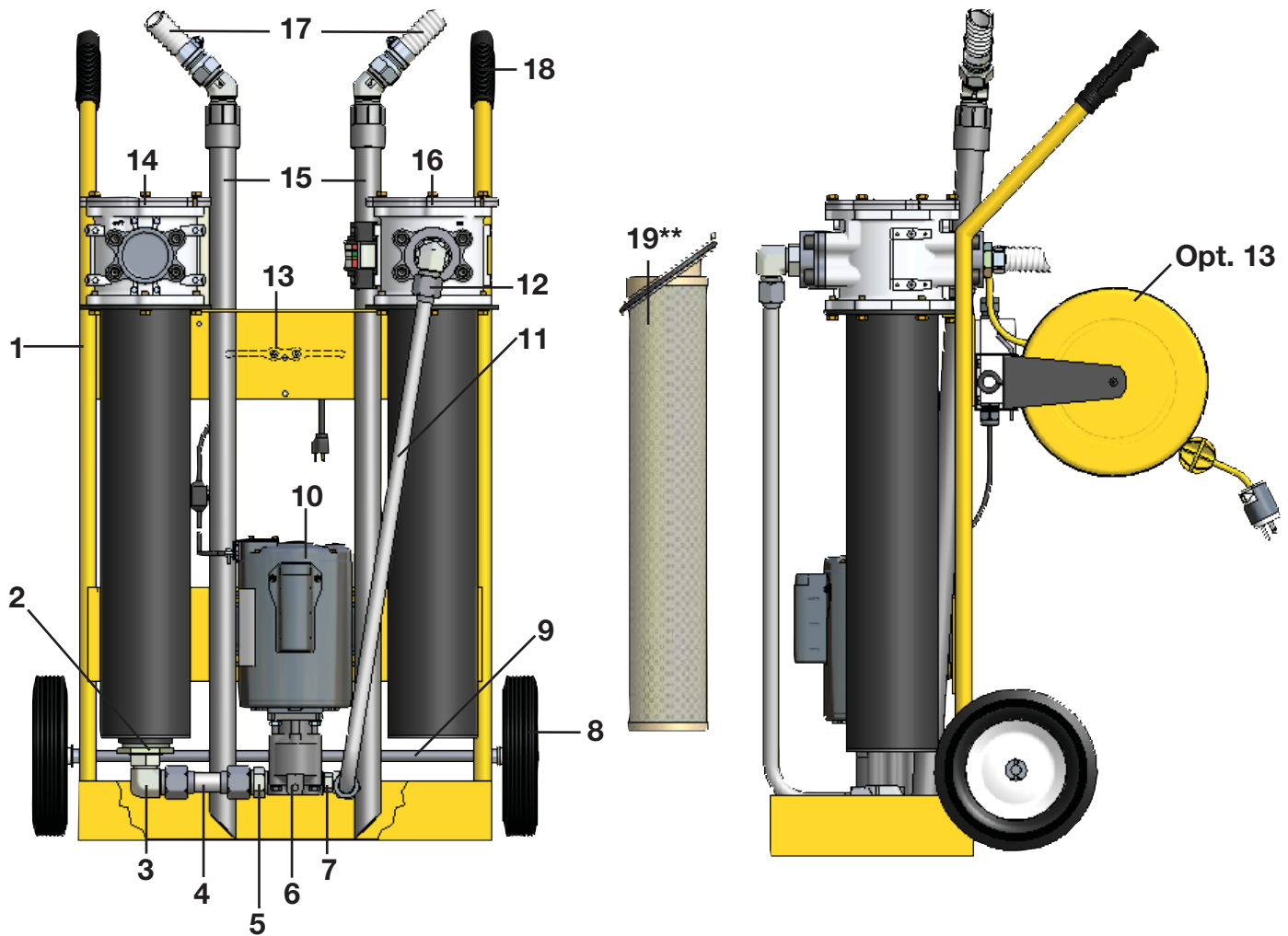

| Item No. | Part No. | Description | Qty |
|----------|----------|----------------------|-----|
| 1 | 928690 | Frame | 1 |
| 2 | 940980 | Pipe Reducer Fitting | 1 |
| 3 | 940979 | Tube Fitting | 1 |
| 4 | 937526 | Suction Tube Assy. | 1 |
| 5 | 928652 | Adapter Fitting | 1 |
| 6 | 928731 | Pump | 1 |
| 7 | 940977 | Adapter Fitting | 1 |
| 8 | 928650 | Wheel | 2 |
| 9 | 928653 | Axle | 1 |
| 10 | 928678 | Motor 10MFP | 1 |
| 10 | 929692 | Motor 5MFP | 1 |
| 11 | 937527 | Discharge Tube Assy. | 1 |
| 12 | 940978 | Tube Fitting | 1 |

| Item No. | Part No. | Description | Qty |
|----------|-------------------------|---------------------------------|-----|
| 13 | 928649 | Cord Cleat | 1 |
| Opt 13 | 928623 | Cord Reel | 1 |
| 14 | RFP-2**-B-PP-3-YN-F9-1 | Inlet Filter – Nitrile | 1 |
| 14 | RFP-2**-V-VP-3-YN-F9-1 | Inlet Filter – Fluorocarbon | 1 |
| 15 | 928784 | Tube Wand Assy. – Seal Option B | 2 |
| 15 | 928620 | Tube Wand Assy. – Seal Option V | 2 |
| 16 | ILP-2**-B-VP-35-YN-YN-1 | Outlet Filter – Nitrile | 1 |
| 16 | ILP-2**-V-VP-35-YN-YN-1 | Outlet Filter – Fluorocarbon | 1 |
| 17 | 928663 | Hose Assy. – Seal Option B | 2 |
| 17 | 928621 | Hose Assy. – Seal Option V | 2 |
| 18 | 928651 | Handle Grip | 2 |
| 19 | See Chart** | Element, (1) Inlet & (1) Outlet | 2 |

**Refer to chart on How to Order page.

How to Order

Select the desired symbol (in the correct position) to construct a model code.

Example:

| BOX 1 | BOX 2 | BOX 3 | BOX 4 | BOX 5 | BOX 6 | BOX 7 | BOX 8 |
|-------|-------|-------|-------|-------|-------|-------|-------|
| 10MFP | 2 | 40SA | 10Q | B | VP | I | 1 |

| BOX 1: Basic Assembly | |
|-----------------------|------------------------------|
| Symbol | Description |
| 5MFP | 5 GPM (3000 SUS MAX.) |
| 10MFP | 10 GPM (500 SUS MAX.) |

| BOX 2: Length | |
|---------------|---------------|
| Symbol | Description |
| 2 | Double |

| BOX 3: Inlet Filter Element | |
|-----------------------------|---|
| Symbol | Description |
| 40SA | Synthetic, 40 micron |
| 40W | Stainless Steel Mesh, 40 micron nominal |
| 20Q | Microglass III, 20 micron |

Please note the bolded options reflect standard options with a reduced lead-time. Consult factory on all other lead-time options.

| BOX 4: Outlet Filter Element | |
|------------------------------|----------------------------------|
| Symbol | Description |
| 02Q | Microglass III, 2 micron |
| 05Q | Microglass III, 5 micron |
| 10Q | Microglass III, 10 micron |
| 20Q | Microglass III, 20 micron |
| WR | Par-Gel™ Water Removal |

| BOX 5: Seals | |
|--------------|------------------------------------|
| Symbol | Description |
| B | Nitrile (NBR) |
| V | High temperature option (FKM/EPDM) |

| BOX 6: Indicator | |
|------------------|---|
| Symbol | Description |
| VP | Visual indicator, 3-band (mounted on Outlet Filter only) |

| BOX 7: Bypass | |
|---------------|--|
| Symbol | Description |
| I | 35 PSID (2.4 bar) (outlet filter element) |

| BOX 8: Options | |
|----------------|--|
| Symbol | Description |
| 1 | None |
| 6 | 20' electrical cord (retractable reel) |
| 9 | Visual indicator on Inlet Filter |

Replacement Elements

| Media | Nitrile Seals | | Fluorocarbon Seals | |
|-------|--|--|--|--|
| | Inlet Filter (3 psid integral bypass) | Outlet Filter (35 psid integral bypass) | Inlet Filter (3 psid integral bypass) | Outlet Filter (35 psid integral bypass) |
| 02Q | N/A | 937397Q | N/A | 937405Q |
| 05Q | N/A | 937398Q | N/A | 937406Q |
| 10Q | N/A | 937399Q | N/A | 937407Q |
| 20Q | 940971Q | 937400Q | 940974Q | 937408Q |
| 40SA | 940802 | N/A | 940972 | N/A |
| 40W | 940803 | N/A | 940973 | N/A |
| WR | N/A | 940734 | N/A | 940736 |

